

TESLA

**SIDE-BY-SIDE  
REFRIGERATOR  
FREEZER**

**RF5100FMBE**

User Manual



Product images are for illustrative purposes only and may differ from the actual product.

## SAFETY WARNINGS

- THIS appliance is intended to be used in household and similar applications such as staff kitchen areas in shops, offices and other working environments; farm houses and by clients in hotels, motels and other residential type environments; bed and breakfast type environments; catering and similar nonretail applications.
- THIS appliance is not intended for use by persons (including children) with reduced physical, sensory or mental capabilities, or lack of experience and knowledge, unless they have been given supervision or instruction concerning use of the appliance by a person responsible for their safety.)
- CHILDREN should be supervised to ensure that they do not play with the appliance. If the supply cord is damaged, it must be replaced by the manufacturer, its service agent or similarly qualified persons in order to avoid a hazard.
- DO not store explosive substances such as aerosol cans with a flammable propellant in this appliance.
- THE appliance has to be unplugged after use and before carrying out user maintenance on the appliance.
- Keep ventilation openings, in the appliance enclosure or in the built-in structure, clear of obstruction.
- Do not use mechanical devices or other means to accelerate the defrosting process, other than those recommended by the manufacturer.
- Do not damage the refrigerant circuit.
- Do not use electrical appliances inside the food storage compartments of the appliance, unless they are of the type recommended by the manufacturer.
- Please abandon the refrigerator according to local regulators for its use flammable blowing gas and refrigerant.
- When positioning the appliance, ensure the supply cord is not trapped or damaged.
- Do not locate multiple portable socket-outlets or portable power supplies at the rear of the appliance.
- DO not use extension cords or ungrounded (two prong) adapters.
- Risk of child entrapment. Before you throw away your old refrigerator or freezer:
  - Take off the doors.
  - Leave the shelves in place so that children may not easily climb inside.
- THE refrigerator must be disconnected from the source of electrical supply before attempting the installation of accessory.
- REFRIGERANT and cyclopentane foaming material used for the appliance are flammable. Therefore, when the appliance is scrapped, it shall be kept away from any fire source and be recovered by a special recovering company with corresponding qualification other than be disposed by combustion, so as to prevent damage to the environment or any other harm.
- This appliance can be used by children aged from 8 years and above and persons with reduce physical sensory or mental capabilities or lack of experience and knowledge if they have been given supervision or instruction concerning use of the appliance in a safe way and understand the hazards involved. Children shall not play with the appliance. Cleaning and user maintenance shall not be made by children without supervision. Children aged from 3 to 8 years are allowed to load and unload refrigerating appliances.
- THE necessity that, for doors or lids fitted with locks and keys, the keys be kept out of the reach of children and not in the vicinity of the refrigerating appliance, in order to prevent children from being locked inside .
- TO avoid contamination of food, please respect the following instructions:
  - Opening the door for long periods can cause a significant increase of the temperature in the compartments of the appliance.
  - Clean regularly surfaces that can come in contact with food and accessible drainage systems.
  - Clean water tanks if they have not been used for 48 h; flush the water system connected to a water supply if water has not been drawn for 5 days. (note 1)
  - Store raw meat and fish in suitable containers in the refrigerator, so that it is not in contact with or drip onto other food.
  - Two-star frozen-food compartments are suitable for storing pre-frozen food, storing or making ice-cream and making ice cubes. (note 2)
  - One-, two- and three-star compartments are not suitable for the freezing of fresh food. (note 3)
  - For appliances without a 4-star compartment: this refrigerating appliance is not suitable for freezing foodstuffs.(note 4)
  - If the refrigerating appliance is left empty for long periods, switch off, defrost, clean, dry, and leave the door open to prevent mould developing within the appliance.

Note 1,2,3,4: Please confirm whether it is applicable according to your product compartment type.

- FOR a freestanding appliance: this refrigerating appliance is not intended to be used as a built-in appliance.
- ANY replacement or maintenance of the LED lamps is intended to be made by the manufacturer, its service agent or similar qualified person.
- This product contains a light source of energy efficiency class (F ).

## Meaning of safety warning symbols



This is a prohibition symbol. Any non-compliance with instructions marked with this symbol may result in damage to the product or endanger the personal safety of the user.



This is a warning symbol. It is required to operate in strict observance of instructions marked with this symbol; or otherwise damage to the product or personal injury may be caused.



This is a cautioning symbol. Instructions marked with this symbol require special caution. Insufficient caution may result in slight or moderate injury, or damage to the product.

This manual contains lots of important safety information which shall be observed by the users.

## Electricity related warnings

- Do not pull the power cord when pulling the power plug of the refrigerator. Please firmly grasp the plug and pull out it from the socket directly.
- To ensure safe use, do not damage the power cord or use the power cord when it is damaged or worn.
- Please use a dedicated power socket and the power socket shall not be shared with other electrical appliances.  
The power plug should be firmly contacted with the socket or else fires might be caused.
- Please ensure that the grounding electrode of the power socket is equipped with a reliable grounding line.
- Please turn off the valve of the leaking gas and then open the doors and windows in case of leakage of gas and other flammable gases. Do not unplug the refrigerator and other electrical appliances considering that spark may cause a fire.
- Do not use electrical appliances on the top of the appliance, unless they are of the type recommended by the manufacturer.

## Warnings for using

- Do not arbitrarily disassemble or reconstruct the refrigerator, nor damage the refrigerant circuit; maintenance of the appliance must be conducted by a specialist.
- Damaged power cord must be replaced by the manufacturer, its maintenance department or related professionals in order to avoid danger.
- The gaps between refrigerator doors and between doors and refrigerator body are small, be noted not to put your hand in these areas to prevent from squeezing the finger. Please be gentle when open the refrigerator door to avoid falling articles.
- Do not pick foods or containers with wet hands in the freezing chamber when the refrigerator is running, especially metal containers in order to avoid frostbite.
- Do not allow any child to get into or climb the refrigerator; otherwise suffocation or falling injury of the child may be caused.
- Do not place heavy objects on the top of the refrigerator considering that objectives may fall when close or open the door, and accidental injuries might be caused.
- Please pull out the plug in case of power failure or cleaning. Do not connect the freezer to power supply within five minutes to prevent damages to the compressor due to successive starts.

## Warnings for placement

- Do not put flammable, explosive, volatile and highly corrosive items in the refrigerator to prevent damages to the product or fire accidents.
- Do not place flammable items near the refrigerator to avoid fires.
- The refrigerator is intended for household use, such as storage of foods; it shall not be used for other purposes, such as storage of blood, drugs or biological products, etc.
- Do not store beer, beverage or other fluid contained in bottles or enclosed containers in the freezing chamber of the refrigerator; otherwise the bottles or enclosed containers may crack due to freezing to cause damages.

## Warnings for energy

1. Refrigerating appliances might not operate consistently (possibility of defrosting of contents or temperature becoming too warm in the frozen food compartment) when sited for an extended period of time below the cold end of the range of temperatures for which the refrigerating appliance is designed.
2. The fact that effervescent drinks should not be stored in food freezer compartments or cabinets or in low-temperature compartments or cabinets, and that some products such as water ices should not be consumed too cold;
3. The need to not exceed the storage time(s) recommended by the food manufacturers for any kind of food and particularly for commercially quick-frozen food in food-freezer and frozen-food storage compartments or cabinets;
4. The precautions necessary to prevent an undue rise in the temperature of the frozen food while defrosting the refrigerating appliance, such as wrapping the frozen food in several layers of newspaper.
5. The fact that a rise in temperature of the frozen food during manual defrosting, maintenance or cleaning could shorten the storage life.

# PROPER USE OF REFRIGERATORS

## Placement

- Before use, remove all packing materials, including bottom cushions, foam pads and tapes inside of the refrigerator; tear off the protective film on the doors and the refrigerator body.
- Keep away from heat and avoid direct sunlight. Do not place the freezer in moist or watery places to prevent rust or reduction of insulating effect.
- Do not spray or wash the refrigerator; do not put the refrigerator in moist places easy to be splashed with water so as not to affect the electrical insulation properties of the refrigerator.
- The refrigerator is placed in a well-ventilated indoor place; the ground shall be flat, and sturdy (rotate left or right to adjust the wheel for leveling if unstable).
- The top space of the refrigerator shall be greater than 30cm, and The refrigerator should be placed against a wall with a free distance more than 10cm to facilitate heat dissipation.
- Spare enough space for convenient opening of the doors and drawers or statement by the distributor.

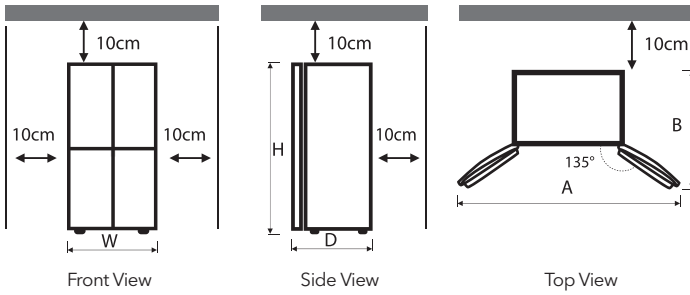

Width "W"	833
Depth "D" (without handle)	653
Height "H"	1898
A	1400
B	1000

The measurements in the above table may differ, depending on the measuring method.

**NOTE** This refrigerator needs to be installed independently and cannot be used as a built-in. Otherwise, it will cause problems such as failure to install into the cabinet, the performance and life of the product are reduced. And the manufacturer does not provide basic product warranty.

- !** Precautions before installation:  
 Before installation or adjusting of accessories, it shall be ensured that the refrigerator is disconnected from power.  
 Precautions shall be taken to prevent fall of the handle from causing any personal injury.

### Levelling feet

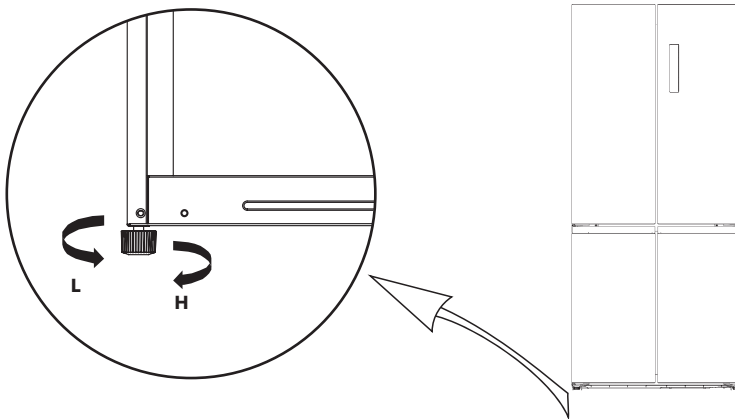

The picture above is only for reference. The actual configuration will depend on the physical product or statement by the distributor.

## Levelling door

List of tools to be provided by the user



plier

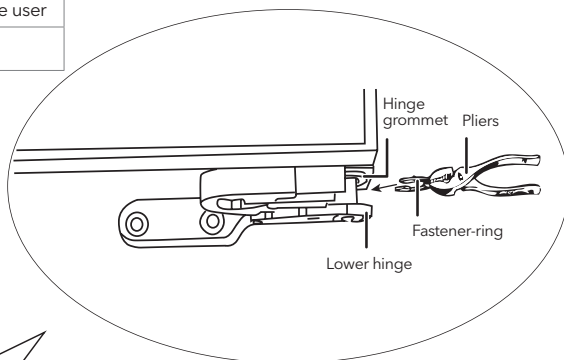
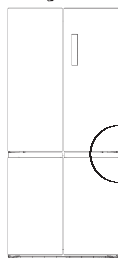
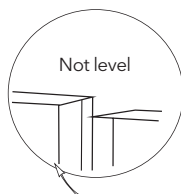

The picture above is only for reference.  
The actual configuration will depend on  
the physical product or statement by the  
distributor.

1. Raise the lower door up to the level of the higher door.
2. Insert the supplied fastener-ring by using plier in the gap between the hinge-grommet and the lower hinge. The number of fastener-rings you will need to insert depends on the gap.

## Changing the Light

Any replacement or maintenance of the LED lamps is intended to be made by the manufacturer, its service agent or similar qualified person.

## Starting to use

- After transportation, please let the product stay for more than 2 hours before turning on the power, otherwise it will lead to a decrease in cooling capacity or a damage to the product.
- Before putting any fresh or frozen foods, the refrigerator shall have run for 2-3 hours, or for above 4 hours in summer when the ambient temperature is high.
- Please pull out the plug in case of power failure or cleaning. Do not connect the freezer to power supply within five minutes to prevent damages to the compressor due to successive starts.

## Energy saving tips

- The appliance should be located in the coolest area of the room, away from heat producing appliances or heating ducts, and out of the direct sunlight.
- Let hot foods cool to room temperature before placing in the appliance. Overloading the appliance forces the compressor to run longer. Foods that freeze too slowly may lose quality, or spoil.
- Be sure to wrap foods properly, and wipe containers dry before placing them in the appliance. This cuts down on frost build-up inside the appliance.
- Appliance storage bin should not be lined with aluminum foil, wax paper, or paper toweling. Liners interfere with cold air circulation, making the appliance less efficient.
- Organize and label food to reduce door openings and extended searches. Remove as many items as needed at one time, and close the door as soon as possible.

# NAMES OF COMPONENTS

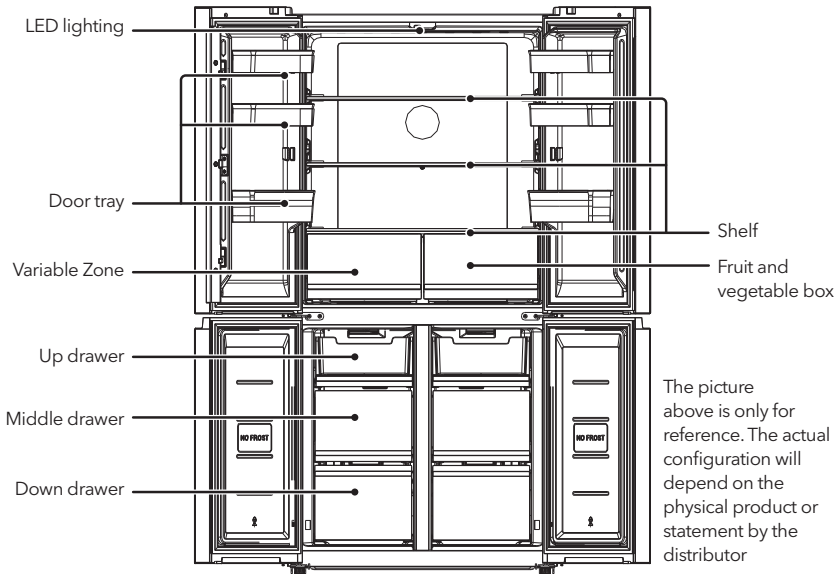

## Refrigerating chamber

- The Refrigerating Chamber is suitable for storage of a variety of fruits, vegetables, beverages and other food consumed in the short term, suggested storage time 3 days to 5 days.
- Cooking foods shall not be put in the refrigerating chamber until cooled to room temperature.
- Foods are recommended to be sealed up before putting into the refrigerator.
- The glass shelves can be adjusted up or down for a reasonable amount of storage space and easy use.

## Freezing chamber

- The low temperature freezing chamber may keep food fresh for a long time and it is mainly used to store frozen foods and making ice.
- The freezing chamber is suitable for storage of meat, fish, rice balls and other foods not to be consumed in short term.
- Chunks of meat are preferably to be divided into small pieces for easy access. Please be noted food shall be consumed within the shelf time.

Drawers, food boxes, shelves, etc. placed according to the position in the picture above are the most energy efficient.

## NOTE

Storage of too much food during operation after the initial connection to power may adversely affect the freezing effect of the refrigerator. Foods stored shall not block the air outlet; or otherwise the freezing effect will also be adversely affected.

## Functions

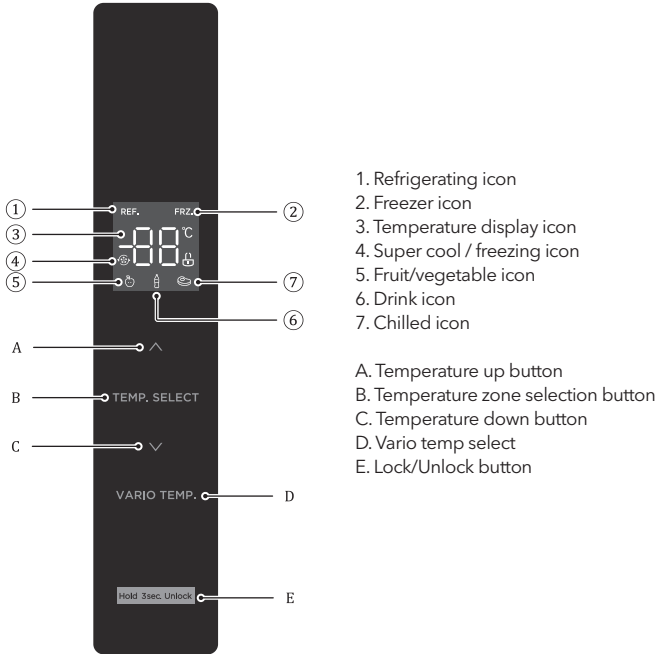

1. Refrigerating icon
2. Freezer icon
3. Temperature display icon
4. Super cool / freezing icon
5. Fruit/vegetable icon
6. Drink icon
7. Chilled icon

- A. Temperature up button  
 B. Temperature zone selection button  
 C. Temperature down button  
 D. Vario temp select  
 E. Lock/Unlock button

### Operation instructions



- Display
 



When electrify the refrigerator, the display screen will total display for 3 seconds. Meanwhile the starting up bell rings and then the screen enters the normal display of the operation.



The first time for using the refrigerator, the default set temperature of refrigerating chamber and freezing chamber is 4° C/-18 °C respectively.



When the error occurs, the display shows the error code (see next page); during normal running, the display shows the set temperature of the refrigerating chamber or freezing chamber.

Under normal circumstances, if there is no operation on display panel or door opening action within 30s, then the display is lock, and the sate  goes out.
- Lock /unlock
 

In the unlocked state, long press the lock button  for 3 seconds, enter the lock state, the logo  goes out and buzzer sounds, it means the display panel is locked, at this time, button operation cannot be implemented;

In the locked state, long press the lock button  for 3 seconds, enter the unlocked state, the logo  lights up and buzzer sounds, it means the display panel is unlocked, at this time, button operation can be implemented;
- Temperature setting of refrigerating chamber
 

Press temperature zone selection button **TEMP. SELECT** to choose the setting temperature zone of refrigerating chamber, and then press  or  to adjust the setting temperature of refrigerating chamber. The temperature setting range for refrigerating chamber is 2°C ~ 8°C.
- Temperature setting of freezing chamber
 

Press temperature zone selection button **TEMP. SELECT** to choose the setting temperature zone of freezing chamber, and then press  or  to adjust the setting temperature of freezing chamber. The temperature setting range for refrigerating chamber is -24°C~ -16°C.



- Temperature setting of variable temperature chamber  
Press Variable temperature button **VARIO TEMP.** to adjust the setting temperature of the chamber, the adjusting range is Fruit/vegetable, drink and chilled.
- Mode setting  
Set the Super cooling mode: after the temperature of the refrigeration room is adjusted to 2°C, press the temperature down button "∨" to enter the super cooling mode. In the super cooling mode, the temperature of the refrigerating chamber is automatically set to 2°C.  
Exit the Super cooling mode: press the temperature up button "∧" to exit the super cooling mode or automatically exit the super cooling mode after 6h.  
After exiting the super cooling mode, the temperature of the refrigerator will automatically return to the temperature set before the super cooling mode  
Set the super freezing mode: after the temperature of the freezing chamber is adjusted to -24°C, press the temperature down button "∨" to enter the super freezing mode. In the super freezing mode, the temperature of the freezing chamber is automatically set to -24°C  
Exit the super freezing mode: press the temperature up button "∧" to exit the super freezing mode or automatically exit the super freezing mode after 32h. After exiting the super freezing mode, the freezing chamber temperature will automatically return to the temperature set before the super freezing mode.

According to IEC62552:2007, the test condition as follow:

start the super freezer mode in advance, and wait when the fridge enters automatic defrosting after 18 hours, and then apply the freezer load. The maximum defrosting time is 72 hours and the minimum is 12 hours at 32°C.

Recommended setting : Refrigerated chamber 4°C freezing chamber -18°C.

#### NOTE

The quick-freezing function is designed to maintain the nutritional value of the food in the freezer. It can freeze the food in the shortest time. If a large amount of food is frozen at one time, it is recommended that the user turn on the quick-freezing function and put the food in. At this time, the freezing speed of the freezer compartment is increased, which can quickly freeze the food, effectively lock the nutrition of the food, and facilitate storage.

- Storage upon power failure  
In case of power failure, the instant working state will be locked and maintained till re-electrification.
- Fault indication  
The following warnings appearing on the display indicate corresponding faults of the refrigerator. Though the refrigerator may still have cold storage function with the following faults, the user shall contact a maintenance specialist for maintenance, so as to ensure optimized operation of the appliance.

Fault code	Fault description
E1	Temperature sensor failure of refrigerating chamber
E2	Temperature sensor failure of freezing chamber
E3	Temperature sensor failure of variable temperature chamber

Fault code	Fault description
E5	Freezing defrost sensor detection circuit error
E6	Communication error
E7	Circulation of temperature detection circuit error
EH	Moisture sensor error

# INSTALLATION INSTRUCTIONS

## For refrigerating appliances with climate class

Depending on the climate class, this refrigerating appliance is intended to be used at ambient temperature ranges as specified following table.

The climate class can be found on the rating plate. The product may not operate properly at temperatures outside of the specified range.

You can find the climate class on the label inside your refrigerator.

## Effective temperature range

The refrigerator is designed to operate normally in the temperature range specified by its class rating.

Class	Symbol	Ambient temperature range °C	
		IEC 62552 (ISO 15502)	ISO 8561
<b>Extended temperat</b>	SN	+ 10 to + 32	+ 10 to + 32
<b>Temperate</b>	N	+ 16 to + 32	+ 16 to + 32
<b>Subtropical</b>	ST	+ 16 to + 38	+ 18 to + 38
<b>Tropical</b>	T	+ 16 to + 43	+ 18 to + 43

## NOTE

The cooling performance and power consumption of the refrigerator may be affected by the ambient temperature, the door-opening frequency, and the location of the refrigerator. We recommend adjusting the temperature settings as appropriate.

## How to store for best preservation (applicable models only)

Cover foods to retain moisture and prevent them from picking up odors from other foods. A large pot of food like soup or stew should be divided into small portions and put in shallow containers before being refrigerated. A large cut of meat or whole poultry should be divided into smaller pieces or placed in shallow containers before being refrigerated.

## Placement of Foods

<b>Shelves</b>	Shelves are adjustable to accommodate a variety of packages
<b>Specialized compartment (applicable models only)</b>	Sealed crisper drawers provide an optimal storage environment for fruit and vegetables. Vegetables require higher humidity while fruit requires lower humidity. Crispers are equipped with control devices to control the humidity level. (*Depending on model and options) An adjustable temperature meat drawer maximizes the storage time of meats and cheeses.
<b>Stored on the door</b>	Don't store perishable foods in the door. Eggs should be stored in the carton on a shelf. The temperature of the storage bins in the door fluctuate more than the temperature in the cabinet. Keep the door closed as much as possible.
<b>Freezer Compartment</b>	You can store frozen food, make ice cubes and freeze fresh food in the freezer compartment.

## NOTE

Freezer fresh, undamaged food only. Keep food which is to be frozen away from food which is already frozen. To prevent food from losing its flavour or drying out, place in airtight containers.

# MAINTENANCE AND CARE OF THE APPLIANCE

## Overall cleaning

- Dusts behind the refrigerator and on the ground shall be timely cleaned to improve the cooling effect and energy saving.
- Check the door gasket regularly to make sure there are no debris. Clean the door gasket with a soft cloth dampened with soapy water or diluted detergent.
- The interior of the refrigerator should be cleaned regularly to avoid odor.
- Please turn off the power before cleaning interior, remove all foods, drinks .shelves, drawers, etc.
- Use a soft cloth or sponge to clean the inside of the refrigerator, with two tablespoons of baking soda and a quart of warm water. Then rinse with water and wipe clean. After cleaning, open the door and let it dry naturally before turning on the power.
- For areas that are difficult to clean in the refrigerator (such as narrow sandwiches, gaps or corners), it is recommended to wipe them regularly with a soft rag, soft brush, etc. and when necessary, combined with some auxiliary tools (such as thin sticks) to ensure no contaminants or bacterials accumulation in these areas.
- Do not use soap, detergent, scrub powder, spray cleaner, etc., as these may cause odors in the interior of the refrigerator or contaminated food.
- Clean the bottle frame, shelves and drawers with a soft cloth dampened with soapy water or diluted detergent. Dry with a soft cloth or dry naturally.
- Wipe the outer surface of the refrigerator with a soft cloth dampened with soapy water, detergent, etc., and then wipe dry.
- Do not use hard brushes, clean steel balls, wire brushes, abrasives (such as toothpastes), organic solvents (such as alcohol, acetone, banana oil, etc.), boiling water, acid or alkaline items, which may damage the fridge surface and interior. Boiling water and organic solvents such as benzene may deform or damage plastic parts.
- Do not rinse directly with water or other liquids during cleaning to avoid short circuits or affect electrical insulation after immersion.



Please unplug the refrigerator for defrost and cleaning.

## Cleaning of door tray

- According to the direction arrow in the figure below, use both hands to squeeze the tray, and push it upward, then you can take it out.
- After washing the tray having been taken out, you can adjust its installing height in accordance with your requirement.

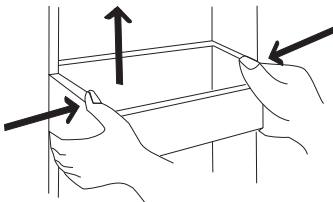

The picture above is only for reference. The actual configuration will depend on the physical product or statement by the distributor.

## Defrosting

- The refrigerator is made based on the air-cooling principle and thus has automatic defrosting function. Frost formed due to change of season or temperature may also be manually removed by disconnection of the appliance from power supply or by wiping with a dry towel.

## Out of operation

- Power failure: In case of power failure, even if it is in summer, foods inside the appliance can be kept for several hours; during the power failure, the times of door opening shall be reduced, and no more fresh food shall be put into the appliance.
- Long-time nonuse: The appliance shall be unplugged and then cleaned; then the doors are left open to prevent odor.
- Moving: Before the refrigerator is moved, take all objects inside out, fix the glass partitions, vegetable holder, freezing chamber drawers and etc. with tape, and tighten the levelling feet; close the doors and fix them with tape. During moving, the appliance shall not be laid upside down or horizontally, or be vibrated; the inclination during movement shall be no more than 45°.



The appliance shall run continuously once it is started. Generally, the operation of the appliance shall not be interrupted; otherwise the service life may be impaired.

## TROUBLESHOOTING

You may try to solve the following simple problems by yourself.  
If them cannot be solved, please contact the after-sales department.

Failed operation	Check whether the appliance is connected to power or whether the plug is in well contact Check whether the voltage is too low Check whether there is a power failure or partial circuits have tripped
Odor	Odorous foods shall be tightly wrapped Check whether there is any rotten food Clean the inside of the refrigerator
Long-time operation of the compressor	Long operation of the refrigerator is normal in summer when the ambient temperature is high It is not suggestible having too much food in the appliance at the same time Food shall get cool before being put into the appliance The doors are opened too frequently
Light fails to get lit	Check whether the refrigerator is connected to power supply and whether the illuminating light is damaged Have the light replaced by a specialist
Doors cannot be properly closed	The door is stuck by food packages The refrigerator is tilted
Loud noise	Check whether the floor is level and whether the refrigerator is placed stably Check whether accessories are placed at proper locations
Door seal fails to be tight	Remove foreign matters on the door seal Heat the door seal and then cool it for restoration (or blow it with an electrical drier or use a hot towel for heating)

Water pan overflows	There is too much food in the chamber or food stored contains too much water, resulting in heavy defrosting The doors are not closed properly, resulting in frosting due to entry of air and increased water due to defrosting
Hot housing	Heat dissipation of the built-in condenser via the housing, which is normal. When housing becomes hot due to high ambient temperature and storage of too much food, it is recommended to provide sound ventilation to facilitate heat dissipation.
Surface condensation	Condensation on the exterior surface and door seals of the refrigerator is normal when the ambient humidity is too high. Just wipe the condensate with a clean towel.
Abnormal noise	Buzz: The compressor may produce buzzes during operation, and the buzzes are loud particularly upon start or stop. This is normal. Creak: Refrigerant flowing inside of the appliance may produce creak, which is normal.

## Warnings for disposal



Refrigerant and cyclopentane foaming material used for the refrigerator are flammable. Therefore, when the refrigerator is scraped, it shall be kept away from any fire source and \ be recovered by a special recovering company with corresponding qualification other than be disposed by combustion, so as to prevent damage to the environment or any other harm.



When the refrigerator is scraped, disassemble the doors, and remove gasket of door and shelves; put the doors and shelves in a proper place, so as to prevent trapping of any child.



Correct Disposal of this product:

This marking indicates that this product should not be disposed with other household wastes throughout the EU. To prevent possible harm to the environment or human health from uncontrolled waste disposal, recycle it responsibly to promote the sustainable reuse of material resources. To return your used device, please use the return and collection systems or contact the retailer where the product was purchased. They can take this product for environmental safe recycling.



# OPOZORILA GLEDE VARNOSTI

- Ta gospodinjstvi aparat je predviden za uporabo v gospodinjstvu in temu podobnih okoljih, kot so kuhinje za osebe v trgovinah, pisarnah in drugih delovnih okoljih, kmetije ter hoteli, moteli in nastanitve drugih vrst, v katerih je ta aparat na voljo gostom, nastanitve z nočitvijo in zajtrkom ter catering in podobni načini uporabe, ki niso namenjeni prodaji.
- Ta aparat ni namenjen osebam (vključno z otroki) s telesnimi, senzoričnimi ali duševnimi okvarami ali pa osebam brez izkušenj in znanja, razen če so pod nadzorom osebe, ki je odgovorna za njihovo varnost, ali pa jim je ta oseba podala navodila za uporabo aparata.
- Da se OTROCI zagotovo ne bodo igrali z aparatom, jih je treba nadzorovati. Če je napajalni kabel poškodovan, ga mora zaradi preprečevanja nevarnosti zamenjati proizvajalec, proizvajalčev pooblaščen servisler ali podobno usposobljena oseba.
- V tem gospodinjstvem aparatu ne shranjujte eksplozivnih snovi, kot so aerosolne pločevinke z vnetljivim potisnim plinom.
- Ko uporabnik neha uporabljati gospodinjstvi aparat in preden opravi njegovo vzdrževanje, ga mora odklopiti z napajanja.
- Poskrbite, da odprtine za prezračevanje v okrovu aparata ali v vgrajeni strukturi ne bodo zamašene.
- Odtaljevanja ne poskušajte pospeševati z mehanskimi napravami ali z drugimi sredstvi, razen s tistimi, ki jih priporoča proizvajalec.
- Ne poškodujte krogotoka hladilne tekočine.
- V predelkih za shranjevanje živil ne uporabljajte električnih naprav, razen če so takšne vrste, ki jo priporoča proizvajalec.
- Hladilnik odstranite v skladu z lokalnimi predpisi, saj so za njegovo delovanje uporabljeni vnetljivi eksplozivni plini in hladilna tekočina.
- Pri nameščanju aparata poskrbite, da napajalni kabel ne bo zagozden ali poškodovan.
- Na zadnji strani aparata ne nameščajte prenosnih električnih razdelilnikov z več vtičnicami ali prenosnih napajalnikov.
- NE uporabljajte podaljševalnih kablov ali neozemljenih adapterjev (z dvema poloma).
- Obstaja tveganje za zaprtje otroka v notranjost aparata. Preden stari hladilnik ali zamrzovalno omaro odstranite:
  - Snemite vrata.
  - Police pustite znotraj aparata, tako da otroci ne bodo mogli zlahka splezati vanj.
- Preden poskušate namestiti dodatno opremo, morate hladilnik odklopiti z vira električnega napajanja.
- 
- HLADILNO SREDSTVO in penasta snov ciklopentan, ki se uporabljata pri aparatu, sta vnetljiva. Zato je treba pri uničevanju poskrbeti, da aparat ni v bližini nobenega vira ognja in da ni odstranjen s sežiganjem, ampak ga predela posebno podjetje za predelavo, ki ima ustrezne kvalifikacije, tako da ne pride do škode za okolje ali kakršne koli druge škode.
- Ta aparat lahko uporabljajo otroci, stari 8 in več let, ter osebe s telesnimi, senzoričnimi ali duševnimi okvarami ali pa osebe brez izkušenj in znanja, če so pod nadzorom ali pa so jim bila podana navodila za varno uporabo aparata in če razumejo nevarnosti, povezane z njegovo uporabo. Otroci se z aparatom ne smejo igrati. Brez nadzora otroci aparata ne smejo čistiti in ga vzdrževati. Otrokom, stari od 3 do 8 let, je v hladilne aparate dovoljeno dajati živila in jih jemati iz njih.
- Pri vratih ali pokrovi, na katerih so nameščene ključavnice s ključi, je treba poskrbeti, da ključi ne bodo na doseg otrok in da ne bodo v bližini hladilnega aparata, tako da se otroci ne bodo mogli zakleniti vanj.
- Da preprečite onesaženje živil, upoštevajte naslednja navodila:
  - Če vrata dlje časa pustite odprta, se temperatura v predelkih aparata lahko precej zviša.
  - Redno čistite površine, ki so v stiku z živilo, in dostopne odvodne sisteme.
  - Če posod za vodo 48 ur niste uporabljali, jih očistite; če iz aparata 5 dni niste jemali vode, sperite sistem za vodo, priključen na dovod vode. (Opomba 1.)
  - Surovo meso in ribe v hladilniku shranjujte v primernih posodah, tako da ta živila ne pridejo v stik z drugimi ali da z njih ne kaplja na druga živila.
  - Predelki za zamrznjena živila, označeni z dvema zvezdicama, so primerni za shranjevanje predhodno zamrznjenih živil, shranjevanje ali izdelovanje sladoleada in izdelovanje ledenih kock. (Opomba 2.)
  - Predelki, označeni z eno, dvema in tremi zvezdicami, niso primerni za zamrzovanje svežih živil. (Opomba 3.)
  - Pri aparatih brez predelka s 4 zvezdicami ta hladilni aparat ni primeren za zamrzovanje živil. (Opomba 4.)
  - Če bo hladilni aparat dlje časa prazen, ga izklopite, odtalite, očistite in osušite, nato pa vrata pustite odprta, da preprečite nastajanje plesni v aparatu.
- Opomba 1, 2, 3, 4. Preverite, ali se nanaša na vrsto predelka v vašem izdelku.
- Pri prostostoječem aparatu: ta hladilni aparat ni namenjen temu, da bi bil uporabljen kot vgradni aparat.

## Pomen simbolov opozoril glede varnosti



To je simbol prepovedi. Če se pojavi kakršna koli neskladnost z navodili, ki so označena s tem simbolom, se lahko izdelek poškoduje ali pa je ogrožena uporabnikova lastna varnost.



To je simbol opozorila. Delovanje mora biti strogo v skladu z navodili, ki so označena s tem simbolom, sicer se lahko izdelek poškoduje ali pa je ogrožena uporabnikova lastna varnost.



To je simbol svarila. Pri navodilih, označenih s tem simbolom, je potrebna posebna previdnost. Zaradi neprevidnosti lahko pride do rahlih ali zmernih telesnih poškodb ali pa poškodb izdelka.

V tem priročniku je veliko pomembnih varnostnih informacij, ki jih morajo uporabniki upoštevati.

## Opozorila, povezana z elektriko

- Ko vlečete vtič napajalnega kabla hladilnika iz vtičnice, ne vlecite kabla. Čvrsto primite vtič in ga neposredno izvlecite iz vtičnice.
- Da poskrbite za varno uporabo, napajalnega kabla ne smete poškodovati ali pa ga uporabljati, če je poškodovan ali iztrošen.
- Uporabljajte temu namenjeno napajalno vtičnico, na katero ne smejo biti priklopljeni še drugi aparati. Vtič napajalnega kabla mora biti trdno priključen v vtičnico, sicer lahko pride do požara.
- Poskrbite, da bo ozemljitveni pol napajalne vtičnice priklopljen na zanesljiv ozemljitveni vod.
- Če pušča plin ali drugi vnetljivi plini, izklopite ventil za ta plin ter nato odprite vrata in okna. Hladilnika in drugih električnih aparatov ne odklopite, saj iskra lahko povzroči požar.
- Na vrhu aparata ne uporabljajte električnih naprav, razen če so takšne vrste, ki jo priporoča proizvajalec.

## Opozorila glede uporabe

- Hladilnika ne razstavljajte in ne sestavljajte po lastni presoji ter ne poškodujte tokokroga hladilne tekočine; vzdrževanje aparata lahko izvaja le strokovnjak.
- Da preprečite nevarnost, mora poškodovani napajalni kabel zamenjati proizvajalec, njegov oddelek za vzdrževanje ali sorodni strokovnjaki.
- Reže med vrati hladilnika ter med vrati in ohišjem hladilnika so ozke; da preprečite stisnjenje prstov, pazite, da z rokami ne boste posegali v ta območja. Vrata hladilnika odpirajte nežno, da predmeti ne bodo padli ven.
- Da preprečite ozeblino, med delovanjem hladilnika ne jemljite živil ali posod, še posebej kovinskih, iz zamrzovalne komore z vlažnimi rokami.
- Nobenemu otroku ne dovolite, da zleze v hladilnik ali spleza nanj, saj se lahko zaduši ali poškoduje zaradi padca.
- Na vrh hladilnika ne postavljajte težkih predmetov, saj lahko ti pri zapiranju ali odpiranju vrat padejo in lahko pride do nenamernih poškodb.
- Pri izpadu napajanja ali čiščenju izvlecite vtič. Da preprečite poškodbe kompresorja zaradi zaporednih zagonov, počakajte pet minut, preden zamrzovalnik spet priklopite na napajanje.

## Opozorila glede postavitve

- Da preprečite poškodbe izdelka ali požar, v hladilnik ne postavljajte vnetljivih, eksplozivnih, hlapnih in močno korozivnih predmetov.
- Da preprečite požar, v bližino hladilnika ne postavljajte vnetljivih predmetov.
- Hladilnik je namenjen uporabi v gospodinjstvu, kot je shranjevanje živil; ne smete ga uporabljati za druge namene, kot je shranjevanje krvi, zdravil ali bioloških zdravil ipd.
- V zamrzovalni komori hladilnika ne shranjujte piva, pijač ali drugih tekočin v steklenicah ali zaprtih posodah, saj te steklenice in posode zaradi zamrzovanja lahko počijo in povzročijo škodo.

## Opozorila glede energije

1. Če so hladilni aparati dlje časa v območju s temperaturo, ki je nižja od tiste, za katero so bili zasnovani, lahko začnejo delovati nedosledno (obstaja možnost odtaljevanja vsebine ali previsoke temperature v predelku za zamrznjena živila).
2. V predelkih ali komorah zamrzovalnika živil ali v predelkih ali komorah z nizko temperaturo ne smete shranjevati gaziranih pijač, določenih proizvodov, kot so ledene kocke, pa ne smete uživati, ko so še premrzli.
3. Pri vseh živilih, zlasti pa pri komercialnih živilih, hitro zamrznjenih v zamrzovalniku za živila in v predelkih ali komorah za shranjevanje zamrznjenih živil, se je treba držati rokov shranjevanja, ki jih priporočajo proizvajalci živil.
4. Da pri odtaljevanju hladilnega aparata preprečite pretirano segrevanje zamrznjenih živil, morate izvesti previdnostne ukrepe, kot je zavijanje zamrznjenih živil v več plasti časopisnega papirja.
5. Treba je upoštevati dejstvo, da se zaradi segrevanja zamrznjenih živil med ročnim odtaljevanjem, vzdrževanjem ali čiščenjem rok shranjevanja lahko skrajša.
6. Pri vratih ali pokrovih, na katerih so nameščene ključavnice s ključi, je treba poskrbeti, da ključi ne bodo na doseg otrok in da ne bodo v bližini hladilnega aparata, tako da se otroci ne bodo mogli zakleniti vanj.

## PRAVILNA UPORABA HLADILNIKOV

### Postavitve

- Pred uporabo odstranite vso embalažo, vključno s spodnjimi blazinicami, blazinicami iz pene in trakovi v notranjosti hladilnika, ter odstranite zaščitno folijo na vratih in ohišju hladilnika.
- Hranite v hladnem prostoru brez neposredne sončne svetlobe. Da preprečite rjavenje ali poslabšanje izolativnosti, zamrzovalnika ne postavljajte v vlažne prostore ali prostore, kjer je polno vode.
- Hladilnika ne pršite in ne spirajte; da ne poslabšate lastnosti električne izolacije hladilnika, ga ne postavljajte v vlažne prostore, kjer ga lahko poškropi voda.
- Hladilnik postavite v dobro prezračen notranji prostor; tla morajo biti ravna in trdna (če je hladilnik nestabilen, kolesce za izravnavanje zavrtite v levo ali v desno).
- Prostor nad hladilnikom mora biti višji od 30 cm, hladilnik pa je treba postaviti ob steno, pri čemer mora zaradi boljšega oddajanja toplote razdalja do stene znašati več kot 10 cm.
- Da boste zlahka odpirali vrata in predale, ob hladilniku pustite dovolj praznega prostora.



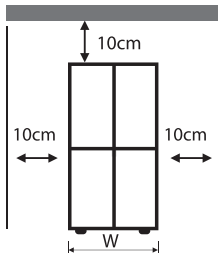

Pogled od spredaj

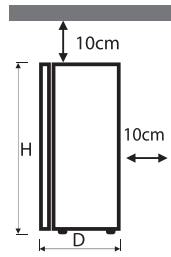

Stranski pogled

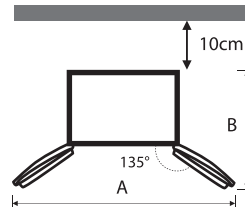

Pogled od zgoraj

Širina "Š"	833
Globina "G" (brez ročaja)	653
Višina "V"	1898
A	1400
B	1000

Meritve v zgornji tabeli se lahko razlikujejo glede na metodo merjenja.

**OPOMBA**

Ta hladilnik je treba namestiti samostojno in ga ni mogoče uporabljati kot vgradnega. V nasprotnem primeru bo prišlo do težav, kot je neuspešna namestitev v ohišje, zmogljivost in življenjska doba izdelka pa se zmanjšata. In proizvajalec ne zagotavlja osnovne garancije za izdelek



Varnostni ukrepi pred namestitvijo:

Pred namestitvijo ali prilagajanjem dodatne opreme se prepričajte, da je hladilnik odklopljen od moči. Sprejeti je treba previdnostne ukrepe, da padec ročaja ne povzroči telesnih poškodb.

## Regulacijski nogici

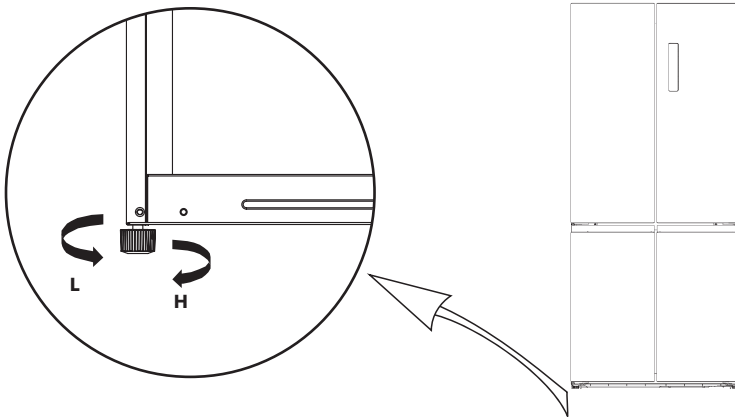

Zgornja slika je namenjena le ponazoritvi. Dejanska postavitev bo odvisna od fizičnega izdelka ali izjave distributerja.

## Izravnavanje vrat

Seznam orodij, ki jih mora priskrbeti uporabnik



Dolge

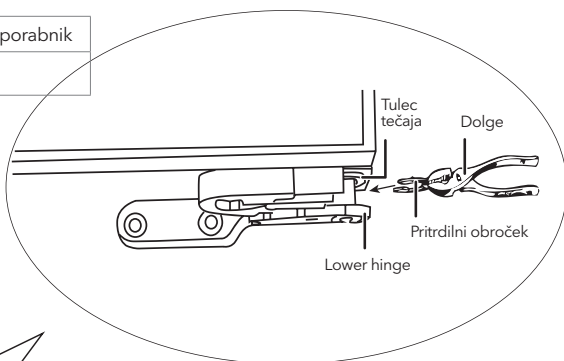

Zgornja slika je namenjena le ponazoritvi. Dejanska postavitev bo odvisna od fizičnega izdelka ali izjave distributerja.

1. Spustite spodnja vrata do nivoja zgornjih vrat.
2. Z dolgimi kleščami vstavite priloženi pritrdilni obroček v režo med tulec tečaja in spodnji tečaj. Število pritrdilnih obročkov, ki jih boste morali vstaviti, je odvisno od reže.

## Zamenjava sijalke

Predvideno je, da kakršno koli zamenjavo ali vzdrževanje sijalk LED izvede proizvajalec, njegov servisni zastopnik ali podobno usposobljena oseba.

## Začetek uporabe

- Preden hladilnik prvič zaženete, ga pred priklopom na napajanje pustite, naj pol ure stoji na svojem mestu.
- Preden vanj shranite kakršna koli sveža ali zamrznjena živila, naj najprej 2-3 deluje, poleti, ko so temperature okolja višje, pa naj deluje več kot 4 ure.
- Da boste zlahka odpirali vrata in predale, ob hladilniku pustite dovolj praznega prostora.
- Zgornja slika je namenjena le ponazoritvi. Dejanska postavitev bo odvisna od fizičnega izdelka ali izjave distributerja.

## Nasveti za varčevanje z energijo

- Aparat naj bo nameščen v najhladnejšem delu prostora, oddaljen naj bo od aparatov, ki proizvajajo toploto, ali od ogrevalnih kanalov in naj ne bo izpostavljen neposredni sončni svetlobi.
- Preden vroča živila shranite v tem aparatu, naj se najprej ohladijo na sobno temperaturo. Če bo aparat preveč napolnjen, bo kompresor deloval dlje. Živila, ki prepočasi zamrzujejo, lahko postanejo manj kakovostna ali pa se pokvarijo.
- Poskrbite, da jih boste pravilno zapakirali in da boste posode do suhega obrisali, preden boste živila shranili v gospodinjski aparat. Na ta način se znotraj aparata tvori manj ledu.
- Predala aparata ne smete oblagati z aluminijasto folijo, papirjem za peko ali papirnatimi brisačami. Material za oblaganje moti kroženje hladnega zraka, zato je aparat manj učinkovit.
- Da boste manjkrat odpirali vrata in ne boste dolgo iskali, živila organizirajte in jih označite. Vzemite čim več živil naenkrat in čim prej zaprite vrata.

# KLJUČNI SESTAVNI DELI

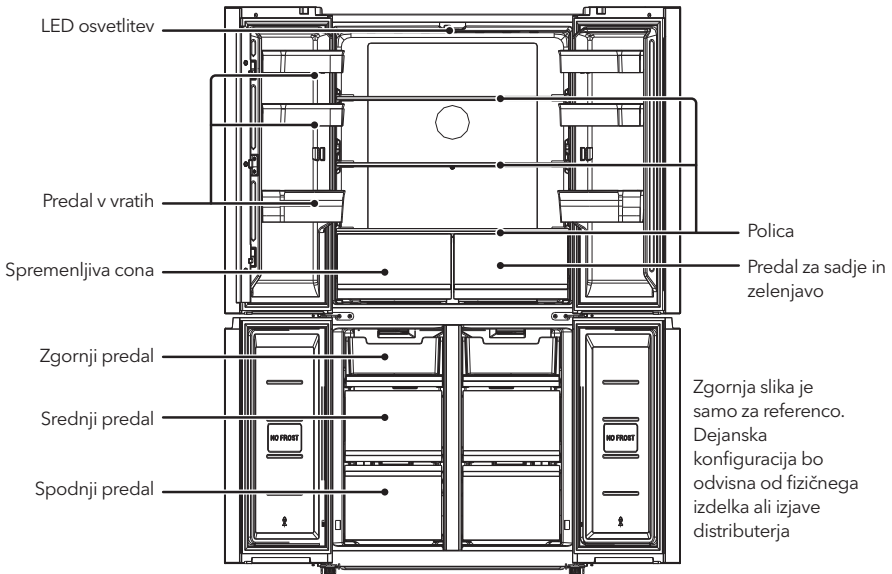

## Hladilna komora

- Hladilna komora je primerna za shranjevanje različnega sadja, zelenjave, pijač in drugih živil, ki jih je treba hitro porabiti.
- Kuhane hrane ne smete shranjevati v hladilni komori, dokler se ne ohladi na sobno temperaturo.
- Pred shranjevanjem v hladilnik je živila priporočljivo zaviti v folijo.
- Višino steklenih polic je mogoče prilagoditi, tako da je velikost prostora za shranjevanje ustrezna, uporaba pa enostavna.

## Zamrzovalna komora

- Nizkotemperaturna zamrzovalna komora lahko ohrani hrano svežo dlje časa in se uporablja predvsem za shranjevanje zamrznjene hrane in izdelavo ledu.
- Zamrzovalna komora je primerna za shranjevanje mesa, rib, riževih kroglic in drugih živil, ki jih ne smete zaužiti v kratkem času.
- Kose mesa je najbolje razdeliti na majhne koščke za hitro zamrzovanje in lažji dostop. Upoštevajte, da je treba hrano zaužiti v času skladiščenja.
- Energijsko najučinkovitejši so predali, škatle za hrano, police itd., ki so nameščeni glede na položaj na zgornji sliki.

### OPOMBA

Shranjevanje preveč hrane med delovanjem po prvi priključitvi na napajanje lahko negativno vpliva na učinek zamrzovanja hladilnika. Shranjena živila ne smejo blokirati izhoda zraka; sicer bo negativno vplival tudi na učinek zamrzovanja.

## Funkcije

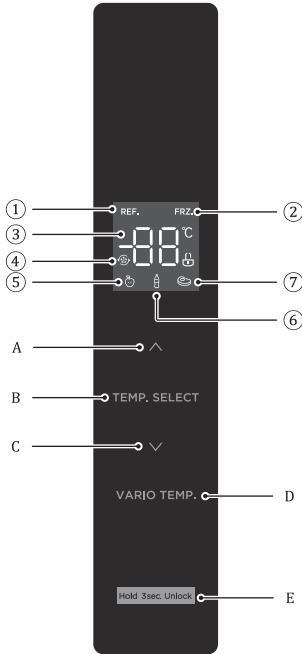

1. Ikona za hlajenje
2. Ikona zamrzovalnika
3. Ikona za prikaz temperature
4. Ikona za super hlajenje/zamrzovanje
5. Ikona za sadje/zelenjava
6. Ikona za pijačo
7. Ikona za ohlajanje

- A. Gumb za dvig temperature
- B. Gumb za izbiro temperaturnega območja
- C. Gumb za znižanje temperature
- D. Variacijska izbira temperature
- E. Gumb za zaklepanje/odklepanje



## Navodila za upravljanje







- Zaslou

Ko hladilnik priključite na elektriko, se na zaslonu prikaže celoten zaslon. Medtem zazvoni zvonec za zagon, nato pa se na zaslonu prikaže normalen prikaz delovanja.

Ob prvi uporabi hladilnika je privzeta nastavljena temperatura hladilne in zamrzovalne komore 4 °C/-18 °C. Ko pride do napake, se na zaslonu prikaže koda napake (glejte naslednjo stran); med normalnim delovanjem se na zaslonu prikaže nastavljena temperatura hladilne komore ali komore za zamrzovanje. Če v normalnih okoliščinah v 30 sekundah ne pride do delovanja na prikazni plošči ali odpiranja vrat, se zaslon zaklene in stanje  ugasne.

- Zaklepanje / odklepanje

V odklenjenem stanju dolgo držite gumb za zaklepanje  3 sekunde, vstopite v stanje zaklepanja, logo  in se oglasi zvočni signal, kar pomeni, da je zaslonka plošča zaklenjena in da v tem času ni mogoče upravljati gumbov;

- V zaklenjenem stanju dolgo držite gumb za zaklepanje  3 sekunde, vstopite v odklenjeno stanje, logo  se prižge in zasliši zvočni signal, kar pomeni, da je zaslonka plošča odklenjena, v tem času je mogoče upravljati z gumbi;
- Nastavitev temperature v hladilni komori  
Pritisnite izbiro temperaturnega območja button **TEMP. SELECT** da izberete temperaturno območje zamrzovalne komore, nato pa pritisnite  ali , da nastavite temperaturo hladilne komore. Območje nastavitve temperature hladilne komore je 2 °C ~ 8 °C.
- Nastavitev temperature v zamrzovalni komori  
Pritisnite gumb za izbiro temperaturnega območja button **TEMP. SELECT** da izberete temperaturno območje zamrzovalne komore, nato pa pritisnite  ali  da prilagodite nastavljeno temperaturo zamrzovalne komore. Območje nastavitve temperature za hladilno komoro je -24 °C ~ -16 °C.
- Nastavitev temperature komore s spremenljivo temperaturo

Pritisnite gumb za spremenljivo temperaturo **VARIO TEMP.** da prilagodite nastavljeno temperaturo komore, razpon nastavitvev je sadje/zelenjava, pijača in ohlajeno.

- **Nastavitev načina**

Nastavitev načina super hlajenja: ko je temperatura v hladilnem prostoru nastavljena na 2 °C, pritisnite gumb za znižanje temperature "∨" da preklopite v način super hlajenja. V načinu super hlajenja se temperatura hladilnega prostora samodejno nastavi na 2 °C.

Izhod iz načina super hlajenja: pritisnite gumb za dvig temperature "∧" da zapustite način super hlajenja, ali pa se način super hlajenja samodejno zaključi po 6 urah.

Po izhodu iz načina super hlajenja se temperatura hladilnika samodejno vrne na temperaturo, nastavljeno pred začetkom načina super hlajenja.

Nastavitev načina super zamrzovanja: ko je temperatura zamrzovalne komore nastavljena na -24 °C, pritisnite gumb za znižanje temperature "∨" da preklopite v način super zamrzovanja. V načinu super zamrzovanja se temperatura komore za zamrzovanje samodejno nastavi na -24 °C.

Izstop iz načina super zamrzovanja: pritisnite gumb za dvig temperature "∧" da izstopite iz načina super zamrzovanja, ali pa se način super zamrzovanja samodejno izklopi po 32 urah. Po izhodu iz načina super zamrzovanja se temperatura zamrzovalne komore samodejno vrne na temperaturo, nastavljeno pred načinom super zamrzovanja.

V skladu z IEC62552:2007 so preskusni pogoji naslednji:

Vnaprej zaženite način super zamrzovalnika in počakajte, ko hladilnik po 18 urah začne samodejno odmrzovanje, nato pa uporabite obremenitev zamrzovalnika. Najdaljši čas odmrzovanja je 72 ur, najmanjši pa 12 ur pri 32 °C.

Priloga nastavitvev : Hladilna komora 4 °C zamrzovalna komora -18 °C.

### OPOMBA

Funkcija hitrega zamrzovanja je zasnovana tako, da ohranja hranilno vrednost živil v zamrzovalniku. Živila lahko zamrzne v najkrajšem času. Če želite naenkrat zamrzniti večjo količino živil, je priporočljivo, da uporabnik vklopi funkcijo hitrega zamrzovanja in vstavi živila. V tem času se poveča hitrost zamrzovanja zamrzovalnega prostora, kar lahko hitro zamrzne živila, učinkovito zaklene hranilne snovi v živilih in olajša shranjevanje.

- **Shranjevanje ob izpadu napajanja**

V primeru izpada električne energije se trenutno delovno stanje zaklene in ohrani do ponovne vključitve.

- **FaultIndikacija napake**

Naslednja opozorila, ki se prikažejo na zaslonu, označujejo ustrezne napake hladilnika. Čeprav ima hladilnik pri naslednjih napakah morda še vedno funkcijo hladilnega shranjevanja, se mora uporabnik za vzdrževanje obrniti na strokovnjaka za vzdrževanje, da se zagotovi optimalno delovanje naprave.

Oznaka napake	Opis napake
E1	Okvara temperaturnega senzorja hladilne komore
E2	Okvara temperaturnega senzorja v zamrzovalni komori
E3	Okvara temperaturnega senzorja v komori s spremenljivo temperaturo

Oznaka napake	Opis napake
E5	Napaka v detektorju zaznavanja zmrzovanja
E6	Komunikacijska napaka
E7	Obtok napake vezja za zaznavanje temperature
EH	Napaka senzorja vlage

# NAVODILA ZA NAMESTITEV

## Za hladilne naprave s klimatskim razredom

Glede na podnebni razred je ta hladilni aparat namenjen uporabi v razponih temperature okolice, kot je določeno v naslednji tabeli.

Podnebni razred je naveden na tipski ploščici. Izdelek morda ne bo pravilno deloval pri temperaturah zunaj navedenega območja.

Podnebni razred lahko najdete na nalepki v notranjosti hladilnika.

## Učinkovito temperaturno območje

Hladilnik je zasnovan tako, da normalno deluje v temperaturnem območju, ki je določeno z njegovim razredom.

Področje	Simbol	Temperaturno območje okolice °C	
		IEC 62552 (ISO 15502)	ISO 8561
Podaljšano zmerno podnebje	SN	+ 10 to + 32	+ 10 to + 32
Zmerni podnebni pas	N	+ 16 to + 32	+ 16 to + 32
Subtropsko podnebje	ST	+ 16 to + 38	+ 18 to + 38
Tropsko podnebje	T	+ 16 to + 43	+ 18 to + 43

### OPOMBA

Na učinkovitost hlajenja in porabo energije hladilnika lahko vplivajo temperatura okolice, pogostost odpiranja vrat in lokacija hladilnika. Priporočamo, da nastavitve temperature ustrezno prilagodite.

## Kako shranjevati, da se čim bolje ohrani (velja samo za modele)

Živila pokrijte, da zadržijo vlago in preprečite, da bi prevzela vonjave drugih živil. Velik lonec hrane, kot je juha ali enolončnica, je treba razdeliti na manjše dele in jih pred shranjevanjem v hladilniku položiti v plitve posode. Velik kos mesa ali celo perutnino je treba razdeliti na manjše kose ali jih pred shranjevanjem v hladilniku položiti v plitve posode.

## Postavitve živil

<b>Police</b>	Police so nastavljive in omogočajo namestitve različnih paketov
<b>Posebni predal (samo pri ustreznih modelih)</b>	Zatesnjeni predali Crisper zagotavljajo optimalno okolje za shranjevanje sadja in zelenjave. Zelenjava potrebuje višjo vlažnost, sadje pa nižjo vlažnost. Predali Crisper so opremljeni z nadzornimi napravami za nadzor ravni vlažnosti. (* Odvisno od modela in možnosti)
<b>Shranjevanje na vratih</b>	V vratih ne shranjujte živil, ki se hitro kvarijo. Jajca shranjujte v škatli na polici. Temperatura posod za shranjevanje v vratih niha bolj kot temperatura v omari. Vrata naj bodo čim bolj zaprta.
<b>Predal z zamrzovalnikom</b>	V zamrzovalniku lahko shranjujete zamrznjena živila, izdelujete ledene kocke in zamrzujete sveža živila.

### OPOMBA

Samo sveža, nepokvarjena živila iz zamrzovalnika. Živila, ki jih je treba zamrzniti, hranite ločeno od že zamrznjenih živil. Da živila ne bi izgubila okusa ali se izsušila, jih postavite v nepredušno zaprte posode

# VZDRŽEVANJE IN NEGA APARATA

## Splošno čiščenje

- Za večji učinek hlajenja in varčevanje z energijo je treba prah za zamrzovalno omaro in na tleh redno čistiti.
- Redno preverjajte tesnilo na vratih, da se na njem ne bo nabirala umazanija. Tesnilo na vratih očistite z mehko krpo, namočeno v milnico ali razredčeni detergent.
- Da preprečite neprijetne vonjave, morate redno čistiti tudi notranjost hladilnika.
- Pred čiščenjem notranjosti izklopite napajanje ter odstranite vsa živila, pijače, police, predale itd.
- Notranjost hladilnika očistite z mehko krpo ali gobo, namočeno v mešanico dveh čajnih žličk sode bikarbone in četrta litra tople vode. Nato izplaknite z vodo in do čistega obrišite. Po čiščenju odprite vrata in pustite, da se notranjost osuši na zraku, preden znova vklopite napajanje.
- Območja, ki jih je težko očistiti (ozke prostore, reže ali kote), je priporočljivo redno brisati z mehko krpo, mehko krtačko itd., po potrebi pa z dodatnimi pripomočki (kot so tanke paličice), da se v njih ne bodo nabirala onesnaževala ali bakterije.
- Ne uporabljajte mil, detergentov, abrazivnih praškov za čiščenje, sredstev za čiščenje v obliki razpršila, saj lahko v notranjosti hladilnika pustijo neprijetne vonjave ali onesnažijo živila.
- Držalo za steklenice, police in predale očistite z mehko krpo, namočeno v milnico ali razredčeni detergent. Obrišite z mehko krpo ali pa pustite, da se posuši na zraku.
- Zunanjo površino hladilnika očistite z mehko krpo, namočeno v milnico, detergent itd., nato pa jo obrišite do suhega.
- Ne uporabljajte trdih krtač, jeklenih gobic za čiščenje, žičnih krtač, abrazivnih sredstev (kot je zobna pasta), organskih topil (kot je alkohol, aceton, bananino olje itd.), vrele vode ali pa kislin ali alkalnih sredstev, ki lahko poškodujejo površino in notranjost hladilnika. Z vrelo vodo in organskimi topili, kot je benzen, se plastični deli lahko deformirajo ali poškodujejo.
- Med čiščenjem ne izplakujte neposredno z vodo ali drugimi tekočinami, da preprečite kratke stike ali poškodbe električne izolacije, ki bi nastale med prelitjem z vodo. Pri odtaljevanju in čiščenju izklopite hladilnik iz napajanja.



## Čiščenje police na vratih

- V skladu s smerno puščico na spodnji sliki z obema rokama pritisnite polico in jo potisnite navzgor, nato pa jo lahko izvlečete.
- Ko izvlečeno polico očistite, lahko višino, na katero jo boste namestili, prilagodite, kot vam ustreza.

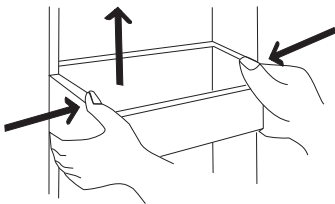

Zgornja slika je namenjena le ponazoritvi. Dejanska postavitev bo odvisna od fizičnega izdelka ali izjave distributerja.

## Odtaljevanje

- Hladilnik je izdelan po načelu hlajenja zraka in ima zato funkcijo samodejnega odtaljevanja. Led, ki se nabere med spremembami letnih časov ali temperature, je mogoče očistiti tudi ročno, tako da aparat izklopite iz napajanja ali pa ga obrišete s suho krpo.

## Nedelovanje aparata

- Izpad napajanja: Če pride do izpada napajanja, je mogoče živila v notranjosti aparata hraniti več ur, tudi če je poletje; med izpadom napajanja morate paziti na to, da vrata odpirate manjkrat in da v aparat ne dajete novih svežih živil.
- Dolgotrajna neuporaba: Aparat morate izključiti iz napajanja in ga nato očistiti ter pustiti vrata odprta, da preprečite neprijetne vonjave.
- Premikanje: Pred premikanjem hladilnika iz njega odstranite vse predmete, steklene dele, predelek za zelenjavo, predale zamrzovalne komore in drugo pa pritrдите z lepilnim trakom; pričvrstite regulacijski nogici, zaprite vrata in jih zalepite z lepilnim trakom. Med premikanjem aparata ne smete obračati, ga polagati vodoravno ali tresti; naklon med premikanjem ne sme znašati več kot 45°.



Ko je aparat zagnan, mora delovati neprekinjeno. V splošnem delovanja aparata ne smete prekinjati, sicer se njegova življenjska doba lahko skrajša.

## ODPRAVLJANJE TEŽAV

Naslednje enostavne težave lahko poskusite odpraviti sami.  
Če jih ne morete odpraviti, se obrnite na poprodajni oddelek.

Aparat ne deluje.	Preverite, ali je aparat priključen na napajanje in ali je stik vtiča dober. Preverite, ali je napetost prenizka. Preverite, ali je prišlo do izpada napajanja ali prekinitev pri določenih tokokrogih.
Neprijetne vonjave	Živila neprijetnih vonjav morate dobro zaviti. Preverite, ali kakšno živilo gnije. Očistite notranjost hladilnika.
Dolgotrajno delovanje kompresorja	Poleti, ko so temperature visoke, je dolgotrajno delovanje hladilnika običajno. V aparatu ni priporočljivo sočasno shranjevati velike količine živil. Živila je treba pred shranjevanjem v aparatu ohladiti. Vrata se prepogosto odpirajo.
Sijalka ne sveti.	Preverite, ali je hladilnik priključen na napajanje in ali je sijalka poškodovana. Sijalko naj zamenja strokovnjak.
Vrat ni mogoče pravilno zapreti.	Vrata ovirajo paketi živil. Hladilnik je nagnjen.
Glasi hrup	Preverite, ali so tla ravna in ali je hladilnik stabilno nameščen. Preverite, ali je dodatna oprema nameščena na ustreznih mestih.
Zdi se, da tesnilo vrat ne tesni.	Odstranite tujke na tesnilu vrat. Tesnilo vrat segrejte in ga nato ohladite, da se vrne v prejšnjo obliko (segrejte jo z električnim fenom ali z vročo brisačo).



Prelivanje iz posode za vodo	V komori je preveč živil ali pa shranjena živila vsebujejo preveč vode, zaradi česar prihaja do precejšnjega odtaljevanja. Vrata niso pravilno zaprta, zato zaradi vstopa zraka prihaja do zamrzovanja, zaradi odtaljevanja pa je povečana količina vode.
Vroče ohišje	Prihaja do oddajanja toplote vgrajenega kondenzatorja prek ohišja, kar je običajen pojav. Ko se ohišje zaradi visoke temperature okolja in shranjevanja prevelike količine živil segreje, je zaradi boljšega oddajanja toplote priporočljivo neprekinjeno prezračevanje.
Kondenzacija na površini	Ko je vlažnost zraka v okolju previsoka, je običajen pojav kondenzacija na zunanjih površinah in tesnilih vrat hladilnika. Kondenzat obrišite s čisto krpo.
Nenormalen hrup	Brenčanje: Kompressor med delovanjem lahko brenči; brenčanje je še zlasti glasno ob začetku in koncu delovanja. To je običajno. Škripanje: Hladilno sredstvo, ki teče po notranjosti aparata, lahko povzroča škripanje, kar je običajno.

## Opozorila glede odstranjevanja



Hladilna tekočina in penasta snov ciklopentan, ki se uporabljata pri hladilniku, sta vnetljivi. Zato je treba pri uničevanju poskrbeti, da hladilnik ni v bližini nobenega vira ognja in da ni odstranjen s sežiganjem, ampak ga predela posebno podjetje za predelavo, ki ima ustrezne kvalifikacije, tako da ne pride škode za okolje ali kakršne koli druge škode.



Pri uničevanju hladilnika razstavite vrata ter z njih odstranite tesnilo in police; vrata in police postavite na primerno mesto, tako da otrokom preprečite zaprtje v hladilnik.



Pravilno odstranjevanje tega izdelka:

Ta oznaka kaže, da tega izdelka nikjer v Evropski uniji ni dovoljeno odlagati skupaj z drugimi gospodinjstskimi odpadki. Za preprečitev morebitne škode za okolje ali zdravje ljudi, ki nastane zaradi nenadzorovanega odlaganja v okolju, izdelek odgovorno reciklirajte, da boste spodbujali trajnostno naravnano ponovno uporabo virov surovin.

Uporabljen napravo vrnite prek sistemov za vračanje in zbiranje ali pa se obrnite na prodajalca, pri katerem ste izdelek kupili. Ta izdelek lahko prevzamejo in reciklirajo izdelek na način, ki je varen za okolje.

TESLA

[tesla.info](https://tesla.info)

