

TESLA

FREE STANDING GAS OVEN

CG5400SW

CG6400SX

User Manual

ENG

CE

Product images are for illustrative purposes only and may differ from the actual product.

Dear User,

We suggest you read the user manual carefully before using the product and keep it at your disposal.

NOTE

This user manual is prepared for more than one model. Some of the features specified in the manual may not be available in your appliance.

All our appliances are only for domestic use, not for commercial use.

IMPORTANT WARNINGS

1. Installation and repair should always be performed by "**AUTHORIZED SERVICE**". Manufacturer shall not be held responsible for operations performed by unauthorized persons.
2. Please read this operating instructions carefully. Only by this way you can use the appliance safely and in a correct manner.
3. The oven should be used according to operating instructions.
4. Keep children below the age of 8 and pets away when operating.
5. **WARNING: The accessible parts may be hot while using the grill. Keep away from children.**
6. **WARNING: Fire hazard; do not store the materials on the cooking surface.**
7. **WARNING: The appliance and its accessible parts are hot during operation.**
8. Setting conditions of this device are specified on the label. (Or on the data plate)
9. The accessible parts may be hot when the grill is used. Small children should be kept away.
10. **WARNING: This appliance is intended for cooking. It should not be used for other purposes like heating a room.**
11. To clean the appliance, do not use steam cleaners.
12. Ensure that the oven door is completely closed after putting food inside the oven.
13. NEVER try to put out the fire with water. Only shut down the device circuit and then cover the flame with a cover or a fire blanket.
14. Children under 8 years of age should be kept away, if they cannot be monitored continuously.
15. Touching the heating elements should be avoided.
16. **CAUTION: Cooking process shall be supervised. Cooking process shall always be supervised.**
17. This device can be used by children over 8 years of age, people with physical, hearing or mental challenges or people with lack of experience or knowledge; as long as control is ensured or information is provided regarding the dangers.
18. This device has been designed for household use only.
19. Children must not play with the appliance. Cleaning or user maintenance of the appliance shall not be performed by children unless they are older than 8 years and supervised by adults.
20. Keep the appliance and its power cord away from children less than 8 years old.
21. Put curtains, tulle, paper or any flammable (ignitable) material away from the appliance before starting to use the appliance. Do not put ignitable or flammable materials on or in the appliance.
22. Keep the ventilation channels open.
23. The appliance is not suitable for use with an external timer or a separate remote control system.
24. Do not heat closed cans and glass jars. The pressure may lead jars to explode.
25. Oven handle is not a towel drier. Do not hang towels, etc. on the oven handle.
26. Do not place the oven trays, plates or aluminium foils directly on the oven base. The accumulated heat may damage the base of the oven.
27. While placing food to or removing food from the oven, etc., always use heat resistant oven gloves.
28. Do not use the product in states like medicated and/or under influence of alcohol which may affect your ability of judgement.
29. Be careful when using alcohol in your foods. Alcohol will evaporate at high temperatures and may catch fire to cause a fire if it comes in contact with hot surfaces.
30. After each use, check if the unit is turned off.
31. If the appliance is faulty or has a visible damage, do not operate the appliance.
32. Do not touch the plug with wet hands. Do not pull the cord to plug off, always hold the plug.
33. Do not use the appliance with its front door glass removed or broken.
34. Place the baking paper together with the food into a pre-heated oven by putting it inside a cooker or on

- an oven accessory (tray, wire grill etc.).
35. Do not put objects that children may reach on the appliance.
 36. It is important to place the wire grill and tray properly on the wire racks and/or correctly place the tray on the rack. Place the grill or tray between two rails and make sure it is balanced before putting food on it.
 37. Against the risk of touching the oven heater elements, remove excess parts of the baking paper that hang over from the accessory or container.
 38. Never use it at higher oven temperatures than the maximum usage temperature indicated on your baking paper. Do not place the baking paper on the base of the oven.
 39. When the door is open, do not place any heavy object on the door or allow children to sit on it. You may cause the oven to overturn or the door hinges to be damaged.
 40. The packaging materials are dangerous for children. Keep packaging materials away from the reach of children.
 41. Do not use abrasive cleaners or sharp metal scrapers to clean the glass as the scratches that may occur on the surface of the door glass may cause the glass to break.
 42. Do not place the appliance on a surface covered with carpets. Electric parts gets overheated since there will be no ventilation from below. This will cause failure of the appliance.
 43. Do not hit glass surfaces of vitro-ceramic cookers with a hard metal, resistance can get damaged. It may cause an electric shock.
 44. User should not handle the oven by himself.
 45. Use shall be careful when cleaning gas burners. It may cause personal injuries.
 46. Food can spill when foot of oven is dismantled or gets broken, be careful. It may cause personal injuries.
 47. During usage, the internal and external surfaces of the oven get hot. As you open the oven door, step back to avoid the hot vapour coming out from the interior. There is risk of burning.
 48. Upper cover of the oven can be closed for a reason, than cookware can trip over. Step back to avoid the hot food coming on you. There is risk of burning.
 49. Do not place heavy objects when oven door is open, risk of toppling.
 50. User should not dislocate the resistance during cleaning. It may cause an electric shock.
 51. Do not remove ignition switches from the appliance. Otherwise, live electric cables can be accessed. It may cause an electric shock.
 52. Oven supply can be disconnected during any construction work at home. After completing the work, re-connecting the oven shall be done by authorized service.
 53. Do not place metal utensils such as knife, fork, spoon on the surface of the appliance, since they will get hot.
 54. To prevent overheating, the appliance should not be installed behind of a decorative cover.
 55. Turn off the appliance before removing the safeguards. After cleaning, install the safeguards according to instructions.
 56. Cable fixing point shall be protected.
 57. **WARNING: Don't use oven and grill burners at same time.**
 58. Please don't cook the food directly on the tray / grid. Please put the food into or on appropriate tools before putting them in the oven.
 59. Hot surface, leave for cooling before closing the cover.
 60. **WARNING: Unattended cooking on a hob with fat or oil can be dangerous and may result in a fire.**
 61. For hobs incorporating halogen lamps the user not to stare at the halogen lamp.
 62. **WARNING: Top burner can be used only for grill.**

Electrical Safety

1. Plug the appliance in a grounded socket protected by a fuse conforming to the values specified in the technical specifications chart.
2. Have an authorized electrician set grounding equipment. Our company shall not be responsible for the damages that shall be incurred due to using the product without grounding according to local regulations.
3. The circuit breaker switches of the oven shall be placed so that end user can reach them when the oven is installed.
4. The power supply cord (the cord with plug) shall not contact the hot parts of the appliance.
5. If the power supply cord (the cord with plug) is damaged, this cord shall be replaced by the manufacturer or its service agent or an equally qualified personnel to prevent a hazardous situation.
6. Never wash the product by spraying or pouring water on it! There is a risk of electrocution.
7. **WARNING: To avoid electric shock, ensure that the device circuit is open before changing the lamp.**
8. **WARNING: Cut off all supply circuit connections before accessing the terminals.**
9. **WARNING: If the surface is cracked, turn off the appliance to avoid risk of electric shock.**
10. Do not use cut or damaged cords or extension cords other than the original cord.

11. Make sure that there is no liquid or humidity in the outlet where the product plug is installed.
12. The rear surface of the oven also heats up when the oven is operated. Electrical connections shall not touch the rear surface, otherwise the connections may be damaged.
13. Do not tighten the connecting cables to the oven door and do not run them over hot surfaces. If the cord melts, this may cause the oven to short circuit and even a fire.
14. Unplug the unit during installation, maintenance, cleaning and repair.
15. If the power supply cable is damaged, it must be replaced by its manufacturer or authorized technical service or any other personnel qualified at the same level, in order to avoid any dangerous situation.
16. Make sure the plug is inserted firmly into wall socket to avoid sparks.
17. Do not use steam cleaners for cleaning the appliance, otherwise electric shock may occur.
18. An omnipolar switch capable to disconnect power supply is required for installation. Disconnection from power supply shall be provided with a switch or an integrated fuse installed on fixed power supply according to building code.
19. Appliance is equipped with a cord cable and EU plug .
20. Fixed connections shall be connected to a power supply enabling omnipolar disconnection. For appliances with over voltage category below III, disconnection device shall be connected to fixed power supply according to wiring code.

Gas Safety

1. This appliance is not connected to burning products evacuation apparatus. This appliance must be connected and installed according to the installation regulations in force. Conditions regarding ventilation must be considered.
2. When a gas cooking appliance is used; humidity, heat and burning products are generated in the room. First of all, make sure the kitchen is well ventilated when operating the appliance and maintain natural ventilation openings or install a mechanical ventilation equipment.
3. After using the appliance heavily for an extended period of time, additional ventilation may be required. For example open a window or adjust a higher speed for mechanical ventilation, if any.
4. This appliance must be used only in well ventilated locations in accordance with the regulations in force. Please read the manual before installing or using this product.
5. Before positioning the appliance, make sure local network conditions (gas type and gas pressure) meets appliance requirements.
6. The mechanism cannot be run for longer than 15 seconds. If the burner is not on after 15 seconds, stop the mechanism and wait for at least one minute before trying to ignite the burner again.
7. All kinds of operations to be performed on gas installation must be performed by authorized and competent people.
8. This appliance is adjusted for natural gas (NG). If you have to use your product with a different gas type, you have to apply to authorized service for the conversion.
9. For proper operation, hood, gas pipe and clamp should be replaced periodically according to manufacturer recommendations and when required.
10. Gas should burn well in gas products. Well burning gas can be understood from blue flame and continuous burning. If gas does not burn sufficiently, carbon monoxide (CO) can be generated. Carbon monoxide is a colourless, odourless and very toxic gas; even small amounts have lethal effect.
11. Ask your local gas supplies about the phone numbers for emergencies related to gas and the measures to be taken upon gas odour is detected.

What To Do When Gas Odour Is Detected

1. Do not use naked flame, and do not smoke.
2. Do not operate any electrical switch. (For example: lamp switch or doorbell)
3. Do not use telephone or mobile phone.
4. Open the doors and windows.
5. Close all valves on the appliances that utilize gas and the gas counters.
6. Call fire brigade from a telephone outside the home.
7. Check all hoses and their connections against leaks. If you still smell gas, leave the house and warn your neighbours.
8. Do not enter into the house until authorities clarify it is safe.

Intended Use

1. This product is designed for home use. Commercial use of the appliance is not permitted.
2. This appliance may only be used for cooking purposes. It shall not be used for other purposes like heating a room.
3. This appliance shall not be used to heat plates under the grill, drying clothes or towels by

hanging them on the handle or for heating purposes.

4. The manufacturer assumes no responsibility for any damage due to misuse or mishandling.
5. Oven part of the unit may be used for thawing, roasting, frying and grilling food.

Electrical Connection

1. Your oven requires 16 or 32 Ampere fuse according to the appliance's power. If necessary, installation by a qualified electrician is recommended.
2. Your oven is adjusted in compliance with 220-240V AC/380-415V AC 50/60Hz electric supply. If the mains are different from this specified value, contact your authorized service.
3. Electrical connection of the oven should only be made by the sockets with earth system installed in compliance with the regulations. If there is no proper socket with earth system in the place where the oven will be placed, immediately contact a qualified electrician. Manufacturer shall never be responsible from the damages that

will arise because of the sockets connected to the appliance with no earth system. If the ends of the electrical connection cable are open, according to the appliance type, make a proper switch installed in the mains by which all ends can be disconnected in case of connecting / disconnecting from / to the mains.

4. If your electric supply cable gets defective, it should definitely be replaced by the authorized service or qualified electricians in order to avoid from the dangers.
5. Electrical cable should not touch the hot parts of the appliance.
6. Please operate your oven in dry atmosphere.

Electrical Connection Scheme

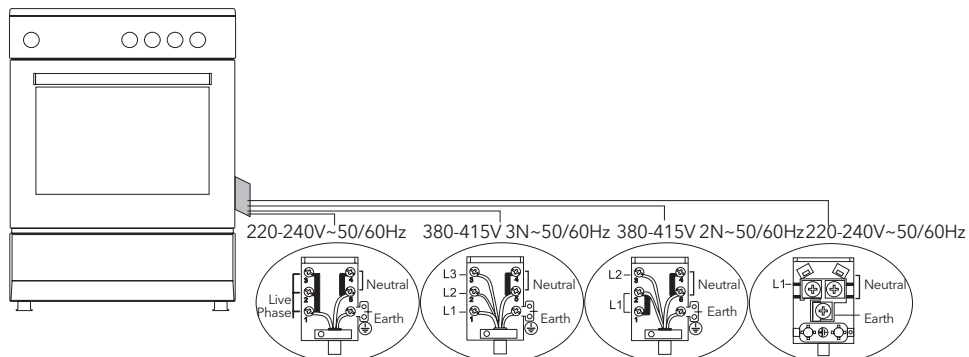

H05 VV-F 3G 4 mm² H05 VV-F 5G 1.5 mm² H05 VV-F 4G 1.5 mm² H05 VV-F 3G 4 mm²

Gas Connection



WARNING!

Before starting any work related with gas installation, turn off gas supply. Risk of explosion.

Please operate your oven in dry atmosphere.

1. Fit the clamp to the hose. Push one of the hose until it goes to the end of the pipe.
2. For the sealing control; ensure that the buttons in the control panel are closed, but the gas cylinder is open. Apply some soap bubbles to the connection. If there is gas leakage, there will be foaming in the soaped area.
3. The oven should be using a well ventilation place and should be install on flat ground.
4. Re-inspect the gas connection.
5. When placing your oven to its location, ensure that it is at the counter level. Bring it to the counter level by adjusting the feet if necessary.
6. Do not make gas hose and electrical cable of your oven go through the heated areas, especially through the rear side of the oven. Do not move gas connected oven. Since the forcing shall loosen the hose, gas leakage may occur.
7. Please use flexible hose for gas connection.

For LPG connection

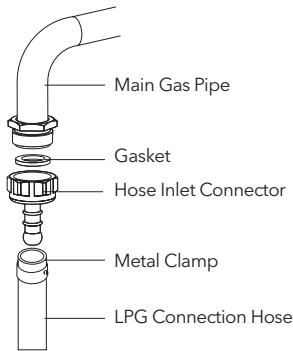

For LPG (cylinder) connection, affix metal clamp on the hose coming from LPG cylinder. Affix an edge of the hose on hose inlet connector behind the appliance by pushing to end through heating the hose in boiled water. Afterward, bring the clamp towards end section of the hose and tighten it with screwdriver. The gasket and hose inlet connector required for connection is as the picture shown below.

NOTE

The regulator to be affixed on LPG cylinder should have 300 mmSS feature.

For natural gas connection

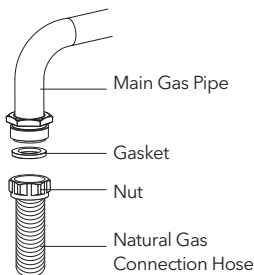

WARNING!

Natural gas connection should be done by authorized service.

For natural gas connection, place gasket in the nut at the edge of natural gas connection hose. To install the hose on main gas pipe, turn the nut. Complete the connection by making gas leakage control.

Gas hose passage way

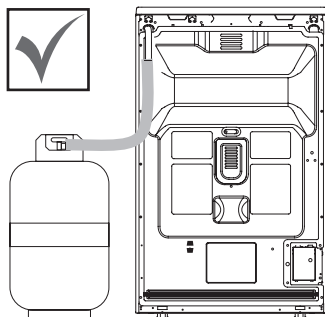

Figure 1

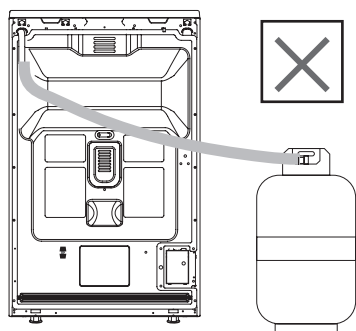

Figure 2

Connect the appliance to the gas piping tap in shortest possible route and in a way that ensure no gas leakage will occur.

In order to carry on a tightness and sealing safety check ensure that the knobs on the control panel are closed and the gas cylinder is open.

WARNING!

While performing a gas leakage check, never use any kind of lighter, match, cigarette or similar burning substance.

Apply soap bubble on the connection points. If there is any kind of leakage then it will cause bubbling. While inserting the appliance in place ensure that it is on the same level with the worktop. If required adjust the legs in order to make level with the worktop. Use the appliance on a level surface and in a well ventilated environment.

WARNING!

Before placing the appliance, check that the local distribution conditions (gas type and pressure) conform to the product settings.

Nozzle change operation

1. Please use driver with special head for removed and install nozzle as. (figure 3)
2. Please remove nozzle (figure 4) from burner with special nozzle driver and install new nozzle. (figure 5)



Figure 3

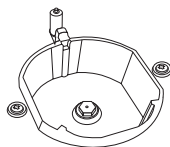

Figure 4

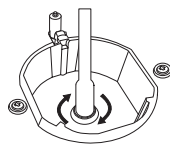

Figure 5

Ventilation of room

The air needed for burning is received from room air and the gases emitted are given directly in room. For safe operation of your product, good room ventilation is a precondition. If no window or room to be utilized for room ventilation is available, additional ventilation should be installed. However, room has a door opening outside, it is no needed to vent holes.

Room size	Ventilating opening
Smaller than 5 m ³	min. 100 cm ²
Between 5 m ³ - 10 m ³	min. 50 cm ²
Bigger than 10 m ³	no need
In basement or cellar	min. 65 cm ²

Reduced gas flow rate setting for hob taps

1. Ignite the burner that is to be adjustment and turn the knob to the reduced position.
2. Remove the knob from the gas tap.
3. Use an appropriately sized screwdriver to adjust the flow rate adjustment screw. For LPG (butane-pro pane) turn the screw clockwise. For the naturel gas, you should turn the screw counter- clockwise once. "The normal length of a straight flame in the reduced position should be 6-7 mm."
4. If the flame is higher then the desired position, turn the screw clockwise. If it is smaller turn anticlockwise.
5. For the last control, bring the burner both to higt-flame and reduced positions and check whether the flame is on or off.

Depending on the type of gas tap used in your appliance the adjustment screw position may vary. To adjust your oven acc. to the gas type, make the adjustment for reduced flame carefully by turning with a small screwdriver as shown below on the screw in the middle of the gas cocks as well as nozzle changes. (figure 6 and 7)

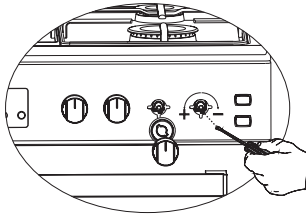

Figure 6

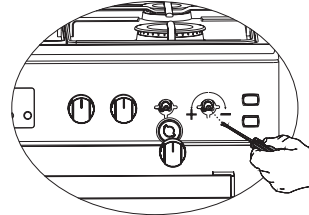
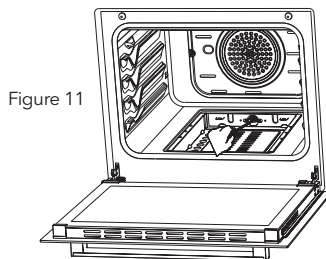
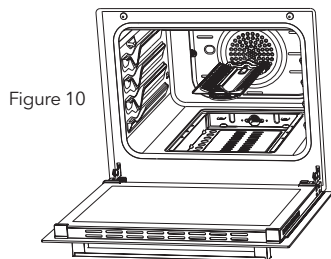
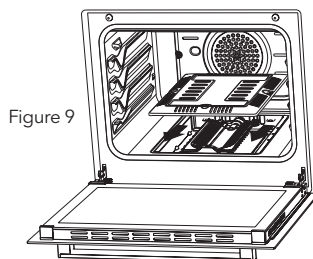
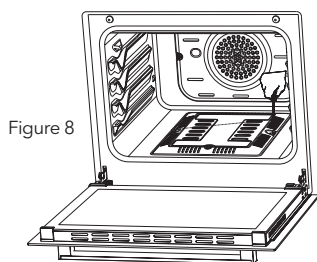

Figure 7

Removal of the lower burner and installation of the injector to the gas oven

The lower burner door has been fixed with two screws. As shown in figure 8, remove it with the help of a screw driver. Remove the door by pulling upwards as shown in figure 9. Remove the burner from its place by pulling it to yourself as shown in figure 10. As shown in figure 11, remove the injector in the bearing with a socket wrench. In order to replace the burner, apply the removal process reversely.



INTRODUCTION OF THE APPLIANCE

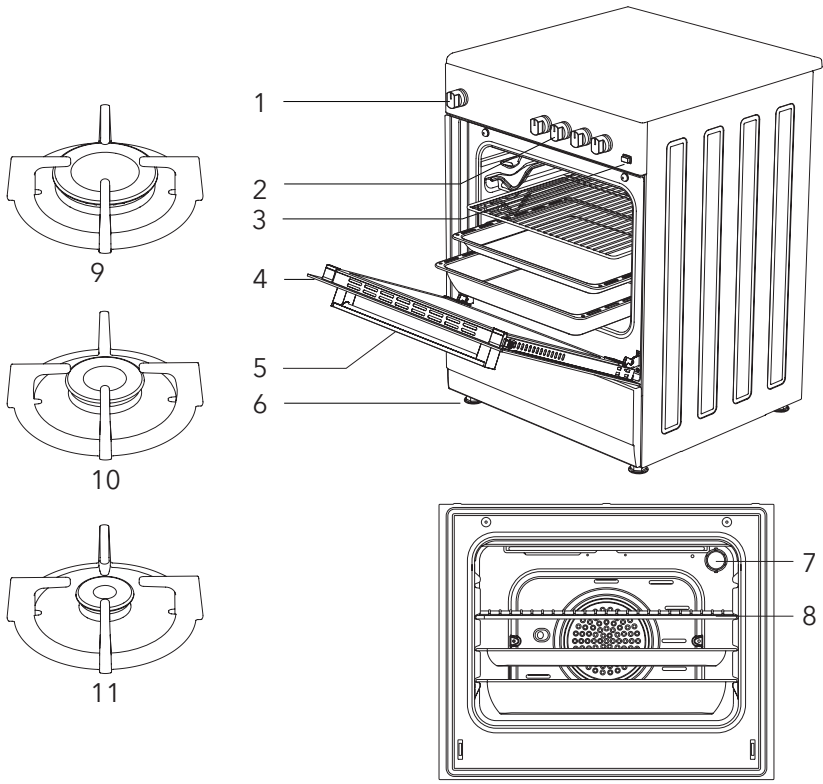

- 1. Oven setting
- 2. Cooker section control Switches
- 3. Button for light
- 4. Door
- 5. Handle
- 6. Plastic leg

- 7. Lamp
- 8. Grill
- 9. Large burner
- 10. Middle burner
- 11. Auxiliary burner

Accessories



Deep tray*

Used for pastry, big roasts, watery foods. It can also be used as oil collecting container if you roast directly on grill with cake, frozen foods and meat dishes.

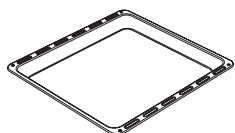

Tray / Glass tray*

Used for pastry (cookie, biscuit etc.), frozen foods.

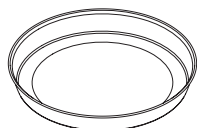

Circular tray*

Used for pastry frozen foods.

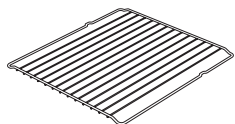

Wire grill

Used for roasting or placing foods to be baked, roasted and frozen into desired rack.



Telescopic rail*

Trays and wire racks can be removed and installed easily thanks to telescopic rails.

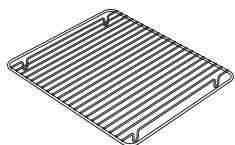

In tray wire grill*

Foods to stick while cooking such as steak are placed on in tray grill. Thus contact of food with tray and sticking are prevented.

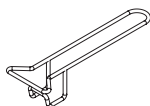

Tray handle*

It is used to hold hot trays.

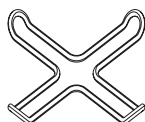

Coffee pot support unit *

Can be used for coffee pot.

Technical features of your oven

Specifications	50x60	60x60
Outer width	500 mm	600 mm
Outer depth	555 mm	610 mm
Outer height	830 mm (860 with plastic leg)	830 mm (860 with plastic leg)
Lamp power	15-25 W	
Supply voltage	220-240V AC/380-415V AC 50/60 Hz	
Left Front Ø55mm	950 W	
Left Rear Ø75mm	1700 W	
Right Front Ø100mm	2900 W	
Right Rear Ø75mm	1700 W	

WARNING!

- **WARNING:** For the modification to be done by authorized service, this table should be considered. Manufacturer may not be held responsible for any problems rising because of any faulty modification.
- **WARNING:** In order to increase the product quality, the technical specifications may be changed without prior notice.
- **WARNING:** The values provided with the appliance or its accompanying documents are laboratory readings in accordance with the respective standards. These values may differ depending on the use and ambient conditions.

Burner Specifications	G20,20 mbar G25,25 mbar			G20,25 mbar		G20,13 mbar	
	Gas natural			Gas natural		Gas natural	
Rapid Burner	Injector	1,15	mm	1,10	mm	1,45	mm
	Gas flow	0,276	m ³ /h	0,276	m ³ /h	0,276	m ³ /h
	Power	2,90	kW	2,90	kW	2,90	kW
Semi-Rapid Burner	Injector	0,97	mm	0,92	mm	1,10	mm
	Gas flow	0,162	m ³ /h	0,162	m ³ /h	0,162	m ³ /h
	Power	1,70	kW	1,70	kW	1,70	kW
Auxiliary Burner	Injector	0,72	mm	0,70	mm	0,85	mm
	Gas flow	0,96	m ³ /h	0,96	m ³ /h	0,96	m ³ /h
	Power	0,95	kW	0,95	kW	0,95	kW
Grill Burner	Injector	1,00	mm	0,92	mm	1,35	mm
	Gas flow	0,196	m ³ /h	0,196	m ³ /h	0,196	m ³ /h
	Power	2,00	kW	2,00	kW	2,00	kW
Oven Burner	Injector	1,10	mm	1,00	mm	1,50	mm
	Gas flow	0,235	m ³ /h	0,235	m ³ /h	0,235	m ³ /h
	Power	2,50	kW	2,50	kW	2,50	kW

Burner Specifications	G30,28-30 mbar G31,37 mbar			G30,50 mbar		G30,37 mbar	
	LPG			LPG		LPG	
Rapid Burner	Injector	0,85	mm	0,75	mm	0,85	mm
	Gas flow	211	m ³ /h	211	m ³ /h	211	m ³ /h
	Power	2,90	kW	2,90	kW	2,90	kW
Semi-Rapid Burner	Injector	0,65	mm	0,60	mm	0,65	mm
	Gas flow	124	m ³ /h	124	m ³ /h	124	m ³ /h
	Power	1,70	kW	1,70	kW	1,70	kW
Auxiliary Burner	Injector	0,50	mm	0,43	mm	0,50	mm
	Gas flow	69	m ³ /h	69	m ³ /h	69	m ³ /h
	Power	0,95	kW	0,95	kW	0,95	kW
Grill Burner	Injector	0,70	mm	0,60	mm	0,65	mm
	Gas flow	145	m ³ /h	145	m ³ /h	145	m ³ /h
	Power	2,00	kW	2,00	kW	2,00	kW
Oven Burner	Injector	0,75	mm	0,65	mm	0,70	mm
	Gas flow	182	m ³ /h	182	m ³ /h	182	m ³ /h
	Power	2,50	kW	2,50	kW	2,50	kW

**WARNING!**

Diameter values written on the injector are specified without a comma. For example; The diameter of 1,70 mm is specified as 170 on the injector.

INSTALLATION OF YOUR OVEN

Check if the electrical installation is proper to bring the appliance in operating condition. If electricity installation is not suitable, call an electrician and plumber to arrange the utilities as necessary. Manufacturer shall not be held responsible for damages caused by operations performed by unauthorized persons.

**WARNING!**

- **WARNING:** It is customer's responsibility to prepare the location the product shall be placed on and also to have the electrical installation prepared.
- **WARNING:** The rules in local standards about electrical installations shall be followed during product installation.
- **WARNING:** Check for any damage on the appliance before installing it. Do not have the product installed if it is damaged. Damaged products cause a risk for your safety.

Right Place for Installation and Important Warnings

- Appliance feet should not stay on soft surfaces such as carpets. The kitchen floor shall be durable to carry the unit weight and any other kitchenware that may be used on the oven.
- Appliance should be used with a clearance of minimum 400 mm over the upper hob surfaces, and 6,5 mm from side surfaces inside a kitchen furniture.
- The appliance is suitable for use on both side walls, without any support, or without being installed in a cabinet. If a hood or aspirator will be installed above the cooker, follow the instructions of the manufacturer for height of mounting. (min. 650 mm)

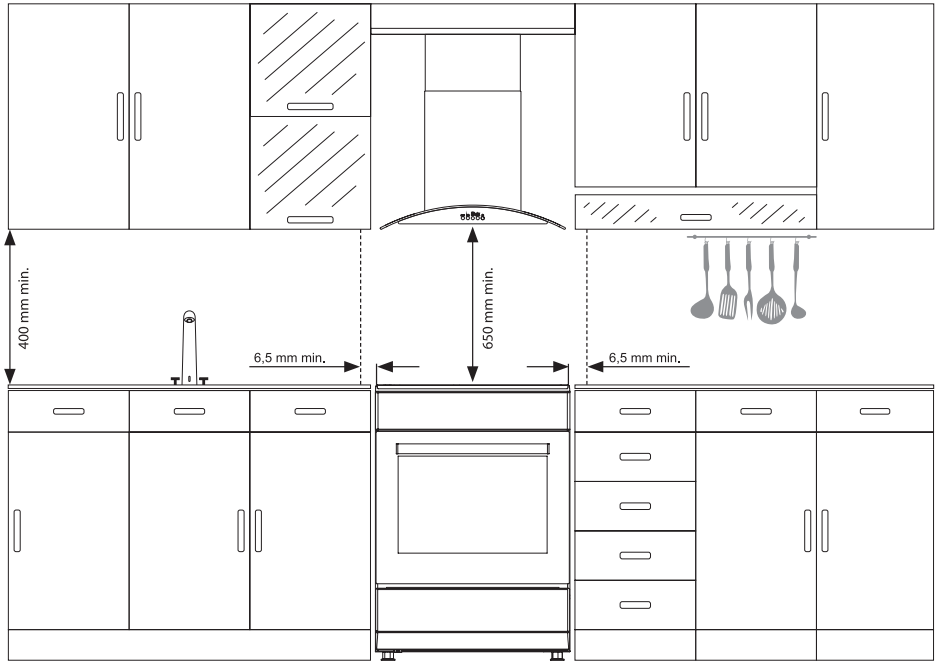
**WARNING!**

- **WARNING:** The kitchen furniture near the appliance must be heat resistant.
- **WARNING:** Do not install the appliance beside refrigerators or coolers. Heat radiated by the appliance increases the energy consumption of cooling devices.
- **WARNING:** Do not use the door and/or handle to carry or move the appliance.

Chain lashing illustration

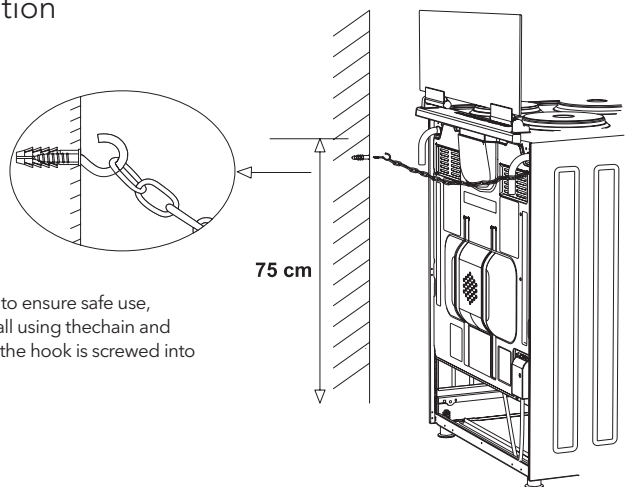

Before using the appliance, in order to ensure safe use, be sure to fix the appliance to the wall using the chain and hooked screw supplied. Ensure that the hook is screwed into the wall securely.

CONTROL PANEL

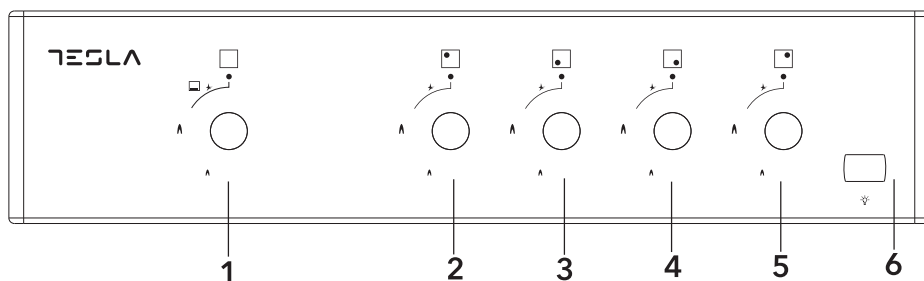

1. Function selection button
2. Rear left heater
3. Front left heater
4. Front right heater
5. Rear right heater
6. Light button



The control panel above is only for illustration purposes. Consider the control panel on your device.

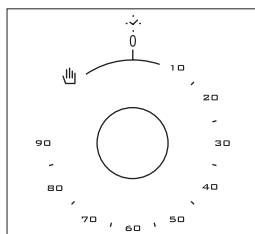

Mechanical timer*: Used for determining the period for cooking in the oven. When adjusted time is expired, power to heaters is turned off and an audible warning signal is emitted. Mechanical timer can be adjusted to desired period between 0-90 minutes. For cooking periods, see cooking tables.

USING OVEN SECTION

Using Oven Burners

1. If your oven equipped with burners that operates with gas, appropriate knob should be used in order to ignite the burners. Some models have automatic ignition from the knob; it is easy to ignite the burner by turning the knob. Also, burners can be ignited by pressing the ignition button or they can be ignited with a match.
2. Do not continuously operate the igniter for more than 15 seconds. If the burner does not ignite, wait minimum one minute before trying again. If the burner is extinguished for of the any reason, close the gas control valve and wait a minimum of one minute before trying again.

Using Oven Heating Elements

1. When your oven is operated first time, an odor will be spread out which will be sourced from using the heating elements. In order to get rid of this, operate it at for 45-60 minutes while it is empty.
2. Oven control knob should be positioned to desired value; otherwise oven does not operate.
3. Kinds of meals, cooking times and thermostat positions are given in cooking table. The values given in the cooking table are characteristic values and were obtained as a result of the tests performed in our laboratory. You can find different flavors suitable for your taste depending on your cooking and using habits.
4. You can make chicken revolving in your oven by means of the accessories.
5. Cooking times: The results may change according to the area voltage and material having different quality, amount and temperatures.
6. During the time when cooking is being performed in the oven, the lid of the oven should not be opened frequently. Otherwise circulation of the heat may be imbalanced and the results may change.

USING COOKER SECTION

Using gas burners

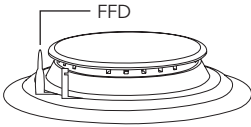

Flame cut-off safety device (FFD); operates instantly when safety mechanism activates due to overflow liquid over upper hobs.



1. The valves controlling the gas cookers have special security mechanism. In order to light the cooker always press on the switch forward and bring it to flame symbol by turnin counter clockwise. All of the lighters shall operate and the cooker you controlled shall light only. Keep the switch pressed until ignition i performed. Press on the lighter button and turn the knob counter clockwise.
2. Do not continuously operate the igniter for more than 15 seconds. If the burner does not ignite, wait minimum one minute before try again.
3. In models with gas security system, when flame of the cooker is extinguished, control valve cuts off the gas automatically. For operate the burners with gas security system you must press the knob and turn counter-clock-wise. After the ignition you must wait nearly 5-10 second for gas security systems activation. If the burner is extinguished for of the any reason, close the gas control valve and wait a minimum of one minute before trying again.
4. ● Closed  Fully open  Half open
5. Before operating your hob please make sure that the burner caps are well positioned. The right placement of the burner caps are shown as below.

Figure 12

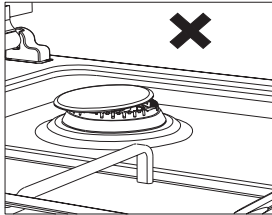
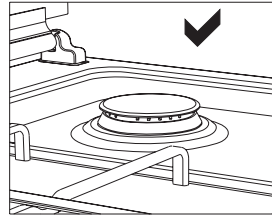

Figure 13



Pot Sizes





	50x60	60x60
Small burner	12-18 cm	12-18 cm
Normal burner	18-20 cm	18-20 cm
Big burner	22-26 cm	22-26 cm

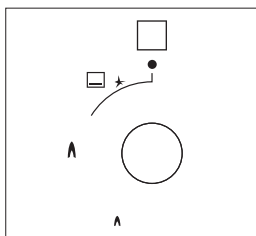

PROGRAM TYPES



Function Button: Used for determining the heaters to be used for cooking the dish to be cooked in the oven. Heater program types in this button and their functions are described below. All heater types and program types consisting of these heaters may not be available at all models.

	Lamp		Lower heating element
	Flame		Ignition lighter



WARNING!

All heater types and program types consisting of these heaters may not be available at all models.

MAINTENANCE AND CLEANING

1. Disconnect the plug supplying electricity for the oven from the socket.
2. While oven is operating or shortly after it starts operating, it is extremely hot. You must avoid touching from heating elements.
3. Never clean the interior part, panel, lid, trays and all other parts of the oven by the tools like hard brush, cleaning mesh or knife. Do not use abrasive, scratching agents and detergents.
4. After cleaning the interior parts of the oven with a soapy cloth, rinse it and then dry thoroughly with a soft cloth.
5. Clean the glass surfaces with special glass cleaning agents.
6. Do not clean your oven with steam cleaners.
7. Before opening the upper lid of the oven, clean spilled liquid off the lid. Also, before closing the lid, ensure that the cooker table is cooled enough.
8. Never use inflammable agents like acid, thinner and gasoline when cleaning your oven.
9. Do not wash any part of your oven in dishwasher.
10. In order to clean the front glass lid of the oven; remove the fixing screws fixing the handle by means of a screwdriver and remove the oven door. Then clean and rinse it thoroughly. After drying, place the oven glass properly and re-install the handle.

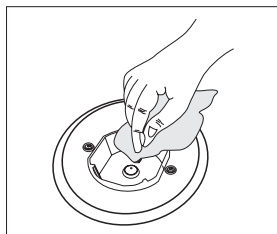

Figure 14

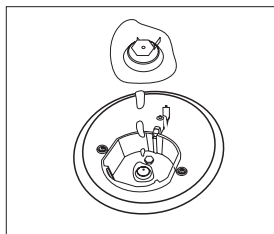

Figure 15

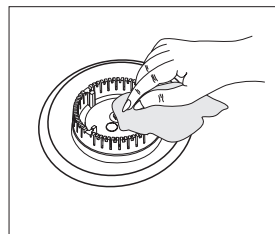

Figure 16

INSTALLATION OF THE OVEN DOOR

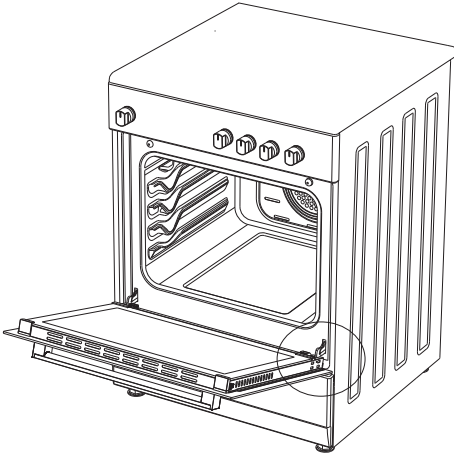

Figure 14

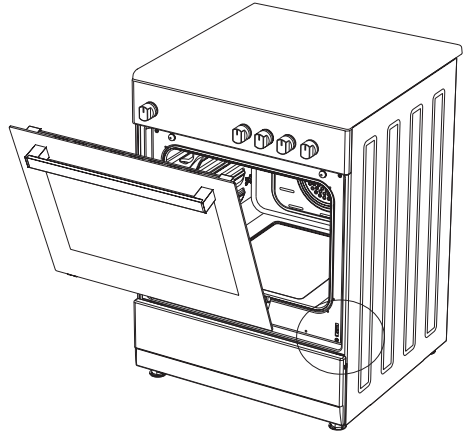

Figure 15

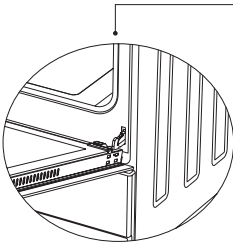

Figure 16.1

Completely open the oven door by pulling it to yourself. After wards, perform the unlocking process by pulling the hinge lock upwards with the help of a screw driver as shown in figure 16.1.

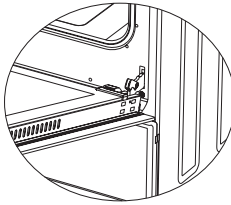

Figure 16.2

Bring the hinge lock to the widest angle as shown in figure 16.2. Bring both hinges connecting the oven door to the oven to the same position.

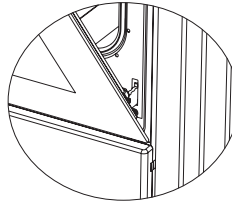

Figure 17.1

Afterwards, close the oven door as to lean on the hinge lock as shown in figure 17.1.

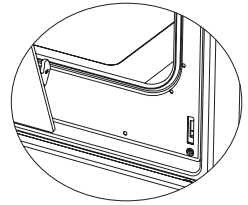

Figure 17.2

To remove the oven door, pull it upwards by holding it with both hands when close to the closed position as shown in figure 17.2.

In order to re-place the oven door, perform the abovementioned steps in reverse.

Cleaning And Maintenance Of The Oven's Front Door Glass

Remove the profile by pressing the plastic latches on both left and right sides as shown in figure 23 and pulling the profile towards yourself as shown in figure 24. Then remove the inner-glass as shown in figure 25. If required, middle glass can be removed in the same way. After cleaning and maintenance are done, remount the glasses and the profile in reverse order. Make sure the profile is properly seated in its place.

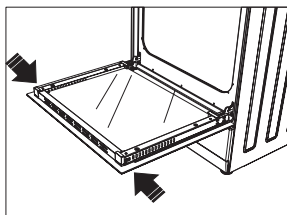

Figure 18

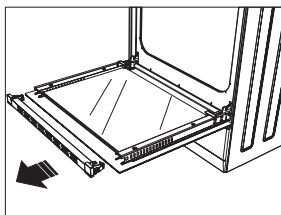

Figure 19

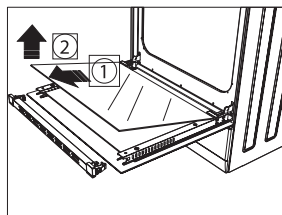

Figure 20

Changing The Oven Lamp



WARNING!

To avoid electric shock, ensure that the appliance circuit is open before changing the lamp. (having circuit open means power is off)

First disconnect the power of appliance and ensure that appliance is cold. Remove the glass protection by turning as indicated in the figure. If you have difficulty in turning, then using plastic gloves will help you in turning.

Then remove the lamp by turning, install the new lamp with same specifications.

Reinstall glass protection, plug the power cable of appliance into electrical socket and complete replacement. Now you can use your oven.

Type G9 Lamp

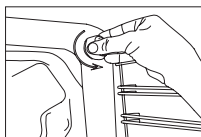

220-240 V, AC 15-25 W

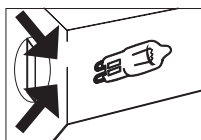

TROUBLESHOOTING

You may solve the problems you may encounter with your product by checking the following points before calling the technical service.

Check Points

In case you experience a problem about the oven, first check the table below and try out the suggestions.

Problem	Possible Cause	What to Do
Oven does not operate.	Power supply not available.	Check for power supply.
	Gas supply not available.	Check if main gas valve is open.
		Check if gas pipe is bent or kinked.
		Make sure gas hose is connected to the oven.
	Check if suitable gas valve is being used.	
Oven stops during cooking.	Plug comes out from the wall socket.	Re-install the plug into wall socket.
Turns off during cooking.	Too long continuous operation.	Let the oven cool down after long cooking cycles.
	More than one plugs in a wall socket.	Use only one plug for each wall socket.
Oven door is not opening properly.	Food residues jammed between the door and internal cavity.	Clean the oven well and try to re-open the door.
Lighter not operating.	Tips or body of ignition plugs are clogged.	Clean tips or body of ignition plugs of gas burners.
	Gas burner pipes are clogged.	Clean gas burner pipes.
Electric shock when touching the oven.	No proper grounding.	Make sure power supply is grounded properly.
	Ungrounded wall socket is used.	
Water dripping.	Water or steam may generate under certain conditions depending on the food being cooked. This is not a fault of the appliance.	Let the oven cool down and than wipe dry with a dishcloth.
Steam coming out from a crack on oven door.		
Water remaining inside the oven.		
Oven does not heat.	Oven door is open.	Close the door and restart.
	Oven controls not correctly adjusted.	Read the section regarding operation of the oven and reset the oven.
	Fuse tripped or circuit breaker turned off.	Replace the fuse or reset the circuit breaker. If this is repeating frequently, call an electrician.
Smoke coming out during operation.	When operating the oven for the first time.	Smoke comes out from the heaters. This is not a fault. After 2-3 cycles, there will be no more smoke.
	Food on heater.	Let the oven to cool down and clean food residues from the heater.

Problem	Possible Cause	What to Do
When operating the oven burnt or plastic odour coming out.	Plastic or other not heat resistant accessories are being used inside the oven.	At high temperatures, use suitable glassware accessories.
Oven does not cook well.	Oven door is opened frequently during cooking.	Do not open oven door frequently, if the food you are cooking does not require turning. If you open the door frequently internal temperature drops and therefore cooking result will be influenced.
Internal light is dim or does not operate.	Foreign object covering the lamp during cooking.	Clean internal surface of the oven and check again.
	Lamp might be failed.	Replace with a lamp with same specifications.

HANDLING RULES

1. Do not use the door and/or handle to carry or move the appliance.
2. Carry out the movement and transportation in the original packaging.
3. Pay maximum attention to the appliance while loading/unloading and handling.
4. Make sure that the packaging is securely closed during handling and transportation.
5. Protect from external factors (such as humidity, water, etc.) that may damage the packaging.
6. Be careful not to damage the appliance due to bumps, crashes, drops, etc. while handling and transporting and not to break or deform it during operation.

RECOMMENDATIONS FOR ENERGY SAVING

Following details will help you use your product ecologically and economically.

1. Use dark coloured and enamel containers that conduct the heat better in the oven.
2. As you cook your food, if the recipe or the user manual indicates that pre-heating is required, pre-heat the oven.
3. Do not open the oven door frequently while cooking.
4. Try not to cook multiple dishes simultaneously in the oven. You may cook at the same time by placing two cookers on the wire rack.
5. Cook multiple dishes successively. The oven will not lose heat.
6. Turn off the oven a few minutes before the expiration time of cooking. In this case, do not open the oven door.
7. Defrost the frozen food before cooking.

ENVIRONMENTALLY-FRIENDLY DISPOSAL



Dispose of packaging in an environmentally-friendly manner.

This appliance is labelled in accordance with European Directive 2012/19/EU concerning used electrical and electronic appliances (waste electrical and electronic equipment - WEEE). The guideline determines the frame work for the return and recycling of used appliances as applicable throughout to the EU.

PACKAGE INFORMATION

Packaging materials of the product are manufactured from recyclable materials in accordance with our National Environment Regulations. Do not dispose of the packaging materials together with the domestic or other wastes. Take them to the packaging material collection points designated by the local authorities.

TESLA

tesla.info